

Therm-O-Flow® 20

334129C
EN

For applying hot melt sealant and adhesive materials from 20 Liter (5 Gallon) pails. For professional use only.

Not approved for use in European explosive atmosphere locations.



Important Safety Instructions

Read all warnings and instructions in this manual and in related manuals. Save these instructions.

*Maximum Operating Temperature 400°F
(204 °C)*

See page 6 for model information.

*See Technical Specifications, page 106,
for maximum working pressures.*

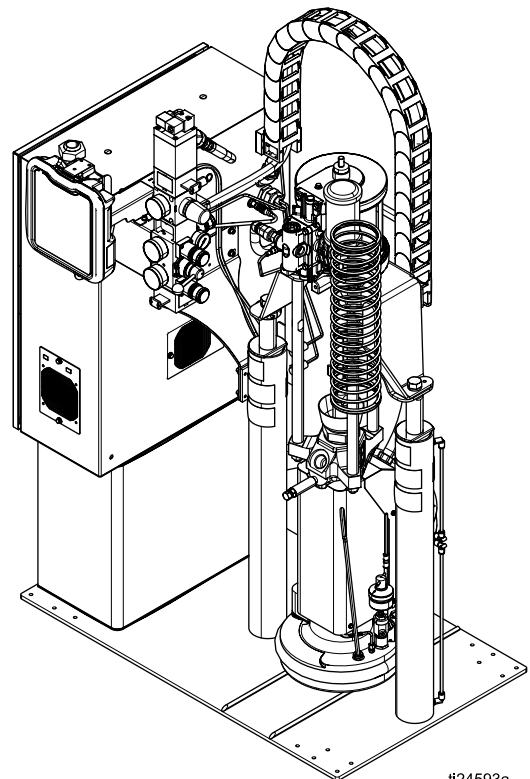

ti24593a















Contents

Warnings	3	Replace Heater Bands and Pump	
Models.....	6	RTD.....	51
Related Manuals	7	Replace MZLP Fuse	52
Component Identification.....	8	Replace MZLP.....	52
Advanced Display Module (ADM).....	12	Replace MZLP Daughter Card	54
Overview.....	15	Replace AWB	55
Air and Fluid Hoses.....	15	Replace Power Supply	55
Heat Control Zone.....	15	Replace Fan.....	56
Setup.....	16	Replace Transformer.....	57
Unpack.....	16	Update Software	59
Location Requirements.....	16	Electrical Schematics.....	60
Install System	16	Parts.....	66
Mechanical Setup	17	Accessories and Kits.....	87
Install Heated Hose	18	Wiper Kits.....	87
Connect Multiple Devices	20	Applicators and Dispense Valves	87
Connect Power	21	Air-Operated Heated Dispense Valves.....	87
Grounding	22	Flow Control and Manifolds	87
Connect Secondary System.....	22	Accessory Extension Cables.....	87
Check Sensor Resistance	23	Light Tower Kit, 24W589	87
Check Heater Resistance	24	Tie Rod Kits.....	87
Select ADM Settings	25	8 Zone Upgrade Kit Installation	91
Connect PLC	27	12 Zone Upgrade Kit Installation	93
Operation.....	30	Appendix A— ADM.....	94
Purge System	30	Operation Screens	96
Load Material.....	31	Setup Screens	97
Heat Up System.....	32	Appendix B — USB Data	102
Prime Pump	33	Download	102
Prime System	35	Access Files	102
Setback Mode.....	35	Upload	102
Pressure Relief Procedure.....	36	USB Logs.....	103
Shutdown	37	System Settings File	103
Schedule	37	System Language File.....	104
Change Pail.....	38	Create Custom Language Strings	104
Troubleshooting.....	39	Dimensions	105
Repair.....	47	Notes	107
Replace Wipers	47	Technical Specifications.....	108
Replace Platen RTD	48	Graco Standard Warranty.....	110
Separate the Air Motor and Pump	49		
Remove Platen	50		

Warnings



The following warnings are for the setup, use, grounding, maintenance, and repair of this equipment. The exclamation point symbol alerts you to a general warning and the hazard symbols refer to procedure-specific risks. When these symbols appear in the body of this manual or on warning labels, refer back to these Warnings. Product-specific hazard symbols and warnings not covered in this section may appear throughout the body of this manual where applicable.

 WARNING	
	<p>BURN HAZARD</p> <p>Equipment surfaces and fluid that is heated can become very hot during operation. To avoid severe burns:</p> <ul style="list-style-type: none"> • Do not touch hot fluid or equipment.
	<p>SPLATTER HAZARD</p> <p>Hot or toxic fluid can cause serious injury if splashed in the eyes or on skin. During blow off of platen, splatter may occur.</p> <ul style="list-style-type: none"> • Use minimum air pressure when removing platen from drum.
 	<p>MOVING PARTS HAZARD</p> <p>Moving parts can pinch, cut or amputate fingers and other body parts.</p> <ul style="list-style-type: none"> • Keep clear of moving parts. • Do not operate equipment with protective guards or covers removed. • Pressurized equipment can start without warning. Before checking, moving, or servicing equipment, follow the Pressure Relief Procedure and disconnect all power sources.
 	<p>ELECTRIC SHOCK HAZARD</p> <p>This equipment must be grounded. Improper grounding, setup, or usage of the system can cause electric shock.</p> <ul style="list-style-type: none"> • Turn off and disconnect power at main switch before disconnecting any cables and before servicing or installing equipment. • Connect only to grounded power source. • All electrical wiring must be done by a qualified electrician and comply with all local codes and regulations.
	<p>TOXIC FLUID OR FUMES HAZARD</p> <p>Toxic fluids or fumes can cause serious injury or death if splashed in the eyes or on skin, inhaled, or swallowed.</p> <ul style="list-style-type: none"> • Read MSDSs to know the specific hazards of the fluids you are using. • Store hazardous fluid in approved containers, and dispose of it according to applicable guidelines.

 WARNING	
	<p>THERMAL EXPANSION HAZARD</p> <p>Fluids subjected to heat in confined spaces, including hoses, can create a rapid rise in pressure due to the thermal expansion. Over-pressurization can result in equipment rupture and serious injury.</p> <ul style="list-style-type: none"> • Open a valve to relieve the fluid expansion during heating. • Replace hoses proactively at regular intervals based on your operating conditions.
	<p>SKIN INJECTION HAZARD</p> <p>High-pressure fluid from dispensing device, hose leaks, or ruptured components will pierce skin. This may look like just a cut, but it is a serious injury that can result in amputation. Get immediate surgical treatment.</p> <ul style="list-style-type: none"> • Engage trigger lock when not dispensing. • Do not point dispensing device at anyone or at any part of the body. • Do not put your hand over the fluid outlet. • Do not stop or deflect leaks with your hand, body, glove, or rag. • Follow the Pressure Relief Procedure when you stop dispensing and before cleaning, checking, or servicing equipment. • Tighten all fluid connections before operating the equipment. • Check hoses and couplings daily. Replace worn or damaged parts immediately.
	<p>FIRE AND EXPLOSION HAZARD</p> <p>Flammable fumes, such as solvent and paint fumes, in work area can ignite or explode. To help prevent fire and explosion:</p> <ul style="list-style-type: none"> • Use equipment only in well ventilated area. • Eliminate all ignition sources; such as pilot lights, cigarettes, portable electric lamps, and plastic drop cloths (potential static arc). • Keep work area free of debris, including solvent, rags and gasoline. • Do not plug or unplug power cords, or turn power or light switches on or off when flammable fumes are present. • Ground all equipment in the work area. See Grounding instructions. • Use only grounded hoses. • Hold gun firmly to side of grounded pail when triggering into pail. Do not use pail liners unless they are antistatic or conductive. • Stop operation immediately if static sparking occurs or you feel a shock. Do not use equipment until you identify and correct the problem. • Keep a working fire extinguisher in the work area.



WARNING

 	<p>EQUIPMENT MISUSE HAZARD</p> <p>Misuse can cause death or serious injury.</p> <ul style="list-style-type: none"> • Do not operate the unit when fatigued or under the influence of drugs or alcohol. • Do not exceed the maximum working pressure or temperature rating of the lowest rated system component. See Technical Data in all equipment manuals. • Use fluids and solvents that are compatible with equipment wetted parts. See Technical Data in all equipment manuals. Read fluid and solvent manufacturer's warnings. For complete information about your material, request MSDS from distributor or retailer. • Do not leave the work area while equipment is energized or under pressure. • Turn off all equipment and follow the Pressure Relief Procedure when equipment is not in use. • Check equipment daily. Repair or replace worn or damaged parts immediately with genuine manufacturer's replacement parts only. • Do not alter or modify equipment. Alterations or modifications may void agency approvals and create safety hazards. • Make sure all equipment is rated and approved for the environment in which you are using it. • Use equipment only for its intended purpose. Call your distributor for information. • Route hoses and cables away from traffic areas, sharp edges, moving parts, and hot surfaces. • Do not kink or over bend hoses or use hoses to pull equipment. • Keep children and animals away from work area. • Comply with all applicable safety regulations.
	<p>PERSONAL PROTECTIVE EQUIPMENT</p> <p>Wear appropriate protective equipment when in the work area to help prevent serious injury, including eye injury, hearing loss, inhalation of toxic fumes, and burns. This protective equipment includes but is not limited to:</p> <ul style="list-style-type: none"> • Protective eyewear, and hearing protection. • Respirators, protective clothing, and gloves as recommended by the fluid and solvent manufacturer.

Models

The model number stamped on your systems defines the equipment in the following categories.

See [Technical Specifications, page 108](#), for maximum working pressure.

SER	A	B	C	D	E
Series	Frame Size	Air Air/Electric	Zone Config	Pump Ratio	Platen Style

Code A	Frame Size
P20	Gallon (20 Liter)
Code B	Air/Electric
A	Air control only
E	Air and Electric
Code C	Zones, Volts, Type
11P	4 Zones, 230 V, Primary
11S	4 Zones, 230 V, Secondary
12P	4 Zones, 400 V/N, Primary
12S	4 Zones, 400 V/N, Secondary
13P	4 Zones, 400 V, Primary
13S	4 Zones, 400 V, Secondary
14P	4 Zones, 480 V, Primary
14S	4 Zones, 480 V, Secondary
15P	4 Zones, 600 V, Primary
15S	4 Zones, 600 V, Secondary
21P	8 Zones, 230 V, Primary
21S	8 Zones, 230 V, Secondary
22P	8 Zones, 400 V/N, Primary
22S	8 Zones, 400 V/N, Secondary
23P	8 Zones, 400 V, Primary
23S	8 Zones, 400 V, Secondary
24P	8 Zones, 480 V, Primary
24S	8 Zones, 480 V, Secondary
25P	8 Zones, 600 V, Primary

25S	8 Zones, 600 V, Secondary
31P	12 Zones, 230 V, Primary
31S	12 Zones, 230 V, Secondary
32P	12 Zones, 400 V/N, Primary
32S	12 Zones, 400 V/N, Secondary
33P	12 Zones, 400 V, Primary
33S	12 Zones, 400 V, Secondary
34P	12 Zones, 480 V, Primary
34S	12 Zones, 480 V, Secondary
35P	12 Zones, 600 V, Primary
35S	12 Zones, 600 V, Secondary
NNN	None
Code D	Pump Ratio
1	23:1 CF (Carbon-Filled)
2	36:1 CF
3	70:1 CF
4	23:1 GF (Glass-Filled)
5	36:1 GF
6	70:1 GF
7	15:1 PTFE
Code E	Platen Style
S	Smooth Bottom (No Fin)
F	Standard Finned Bottom

Related Manuals

Manual	Description
Air Motor Manuals	
306982	President® Air Motor, Instructions-Parts
311238	NXT® Air Motor, Instructions-Parts
3A1211	Saniforce® Air Motor, Instructions-Parts
Displacement Pump Manual	
334127	Check-Mate® 800 Pump, Repair-Parts
334128	Check-Mate 800 Throat Seal Repair Kit, Repair-Parts

Manual	Description
307431	Displacement Pump, Carbon Steel, Instructions-Parts
Ram Manual	
334198	Therm-O-Flow Ram, Instructions-Parts
Accessory and Kit Manuals	
309160	Heated Hose, Instructions-Parts
309196	Wiper Kits, Repair-Parts
310538	Air-Operated Dispense Valves, Instructions-Parts
311209	Top Feed and Bottom Feed Hot Melt Dispense Guns, Instructions-Parts
334201	Air Controls, Repair Kit

Component Identification

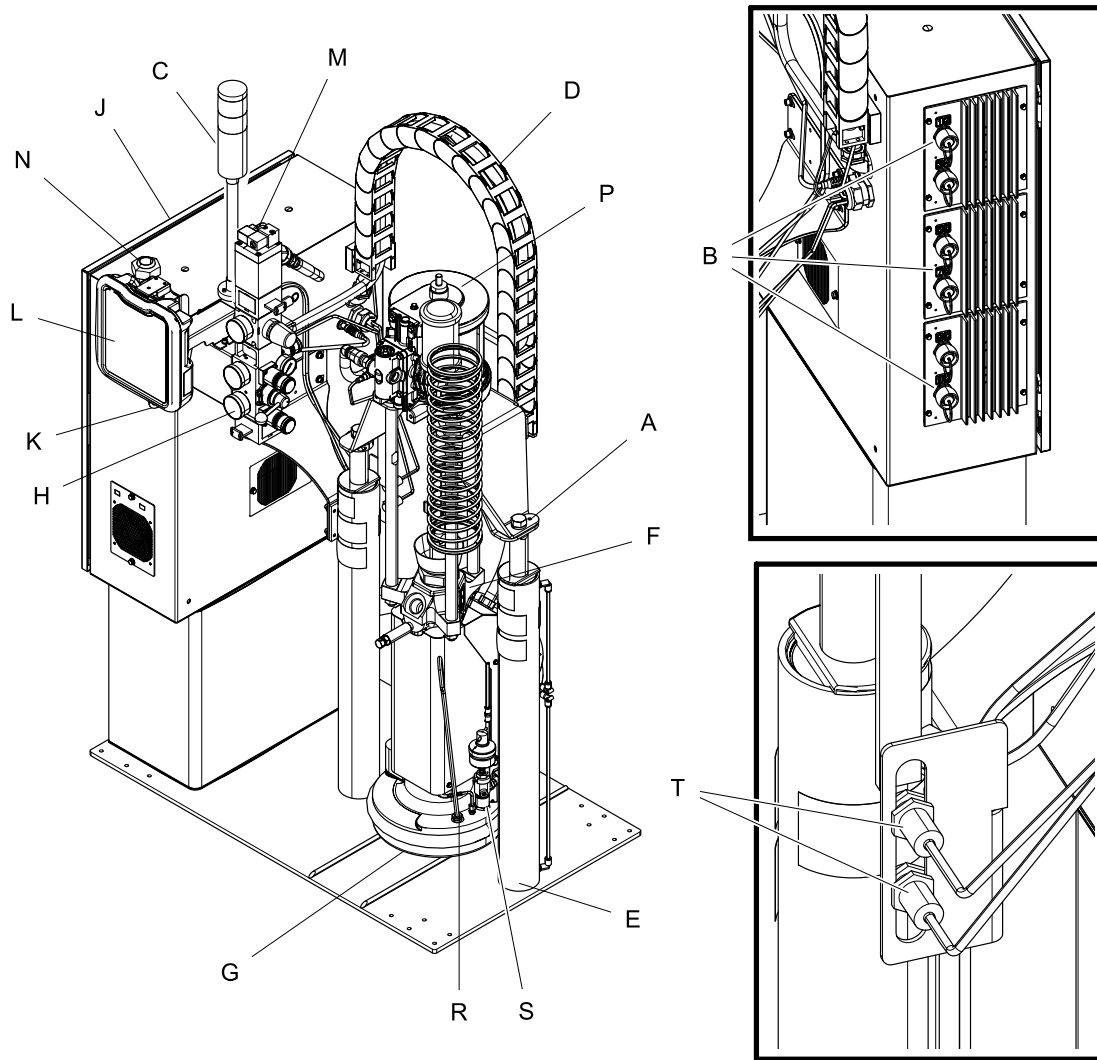

Figure 1 TOF 20

Key:

- A Lift Strap Positions
- B Multi-Zone Low Power Temperature Control Module (MZLP)
- C Light Tower
- D Cable Track
- E Ram
- F Heated Pump
- G Heated Platen
- H Integrated Air Controls (3/4 in npt inlet)
- J Electrical Control Panel

Key:

- K Main Power Switch
- L ADM
- M Air Motor Solenoid
- N Electrical Power Input
- P Air Motor
- R Ram Plate Bleed Stick
- S Drum Blow Off Valve (behind ram plate bleed stick)
- T Drum Low and Empty Sensors

t24594a

Integrated Air Controls

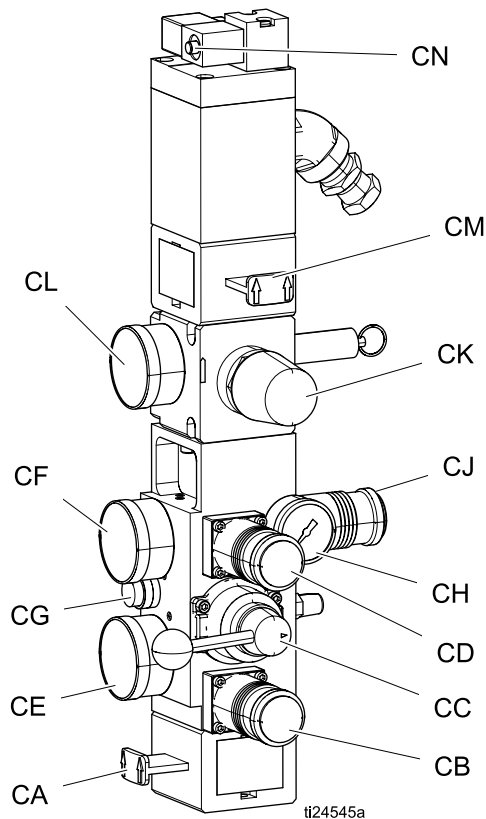

Figure 2 Integrated Air Controls

Key:

- CA Main Air Slider Valve**
Turns air on and off to the entire system. When closed, the valve relieves pressure downstream.
- CB Ram Down Air Regulator**
Controls the ram down pressure.
- CC Ram Director Valve**
Controls the ram direction.
- CD Ram Up Air Regulator**
Controls the ram up pressure.
- CE Ram Down Air Gauge**
Displays the ram down pressure.
- CF Ram Up Air Gauge**
Displays the ram up pressure.
- CG Blowoff Button**
Turns air on and off to push the platen out of an empty drum.

Key:

- CH Blowoff Pressure Gauge**
Displays the blowoff pressure.
- CJ Blowoff Air Regulator**
Controls platen blowoff pressure.
- CK Air Motor Air Regulator**
Controls the air pressure to the motor.
- CL Air Motor Pressure Gauge**
Displays the air pressure to the motor.
- CM Air Motor Slider Valve**
Turns air on and off to the air motor. When closed, the valve relieves air trapped between it and the motor. Push the valve in to shutoff air.
- CN Air Motor Solenoid Valve**
Turns air on and off to the air motor when system stopped on the ADM. When closed, the valve relieves air trapped between it and the motor.

Electrical Control Enclosure

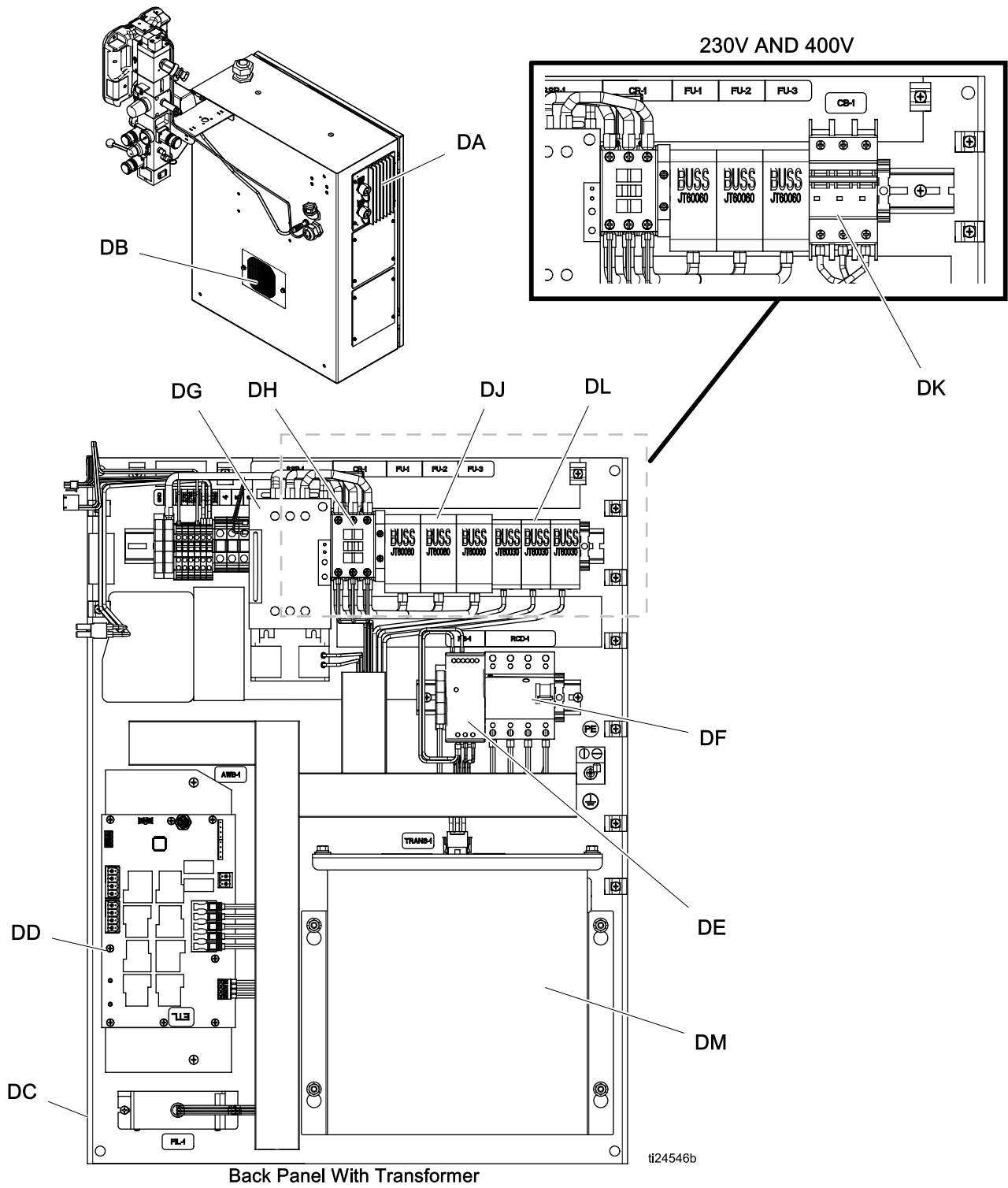

Figure 3 Electrical Enclosure

Component Identification

Key:

DA	Multi-Zone Low Power Temperature Control Module (MZLP)
DB	Ventilation Grill
DC	Electrical Control Panel
DD	Automatic Wiring Board (AWB)
DE	Power Supply (24V)
DF	Residual Current Device (GFI), 63A

Key:

DG	Platen SSR (65A)
DH	Platen Contactor
DJ	Platen Fuse
DK	Transformer Circuit Breaker
DL	Transformer Fuse
DM	Transformer

Advanced Display Module (ADM)

The ADM display shows graphical and text information related to setup and spray operations.

For detail on the display and individual screens, see [Appendix A— ADM, page 94](#).

Use the USB port on the ADM to download or upload data. For more information about the USB data, see [Appendix B — USB Data, page 102](#).

NOTICE

To prevent damage to the softkey buttons, do not press buttons with sharp objects such as pens, plastic cards, or fingernails.

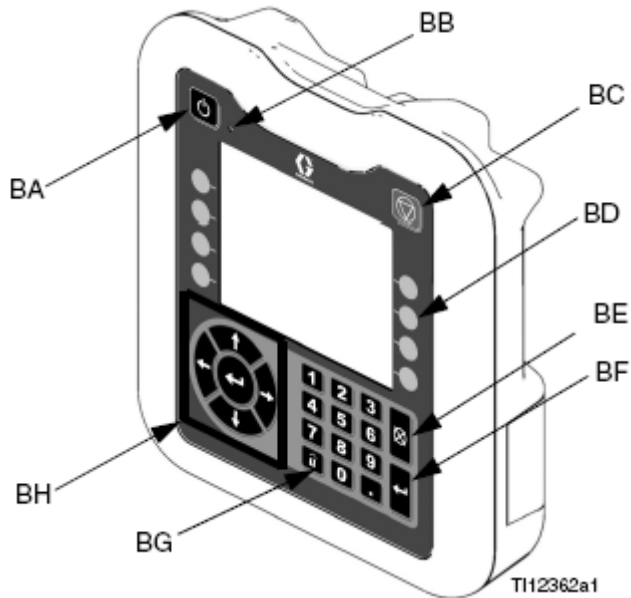

Figure 4 Front View

Key	Function
BA	Heating system and pump enable/disable
BB	System status indicator (LED)
BC	Stop all system processes
BD	Defined by icon next to softkey
BE	Abort current operation
BF	Accept change, acknowledge error, select item, toggle selected item
BG	Toggle between Operation and Setup screens
BH	Navigate within a screen or to a new screen

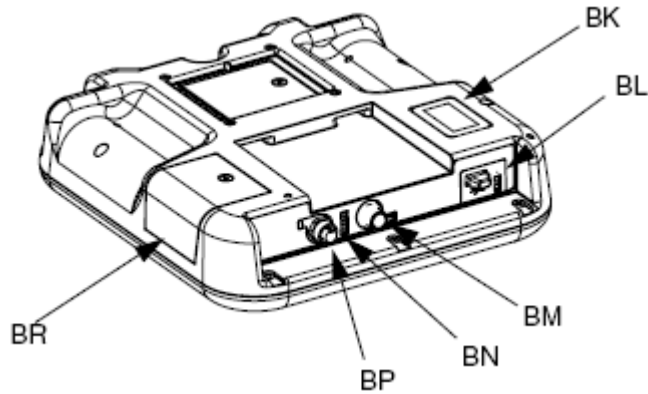



Figure 5 Back View

BK	Part Number and Identification Label
BL	USB Interface
BM	CAN Cable Connection (Power Supply and Communication)

BN	Module Status LEDs
BP	Light Tower (Optional)
BR	Software Token Access Panel

Table 1 ADM LED Status Descriptions

LED	Conditions	Description
System Status 	Green Solid	Run Mode, System On
	Green Flashing	Setup Mode, System On
	Yellow Solid	Run Mode, System Off
USB Status (BL)	Green Flashing	Data recording in progress
	Yellow Solid	Downloading information to USB
	Green and Yellow Flashing	ADM is busy, USB cannot transfer information when in this mode
ADM Status (BN)	Green Solid	Power applied to module
	Yellow Solid	Active Communication
	Red Steady Flashing	Software upload from token in progress
	Red Random Flashing or Solid	Module error exists

Screen Components

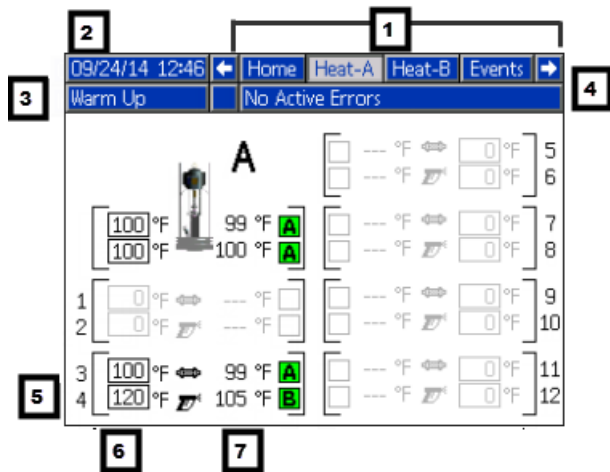

1. Screen Order
2. Current date and time
3. Operating Mode
4. Faults, Status
5. MZLP Plug Identifier
6. Zone Setpoint Temperature
7. Zone Actual Temperature

Operating Mode	Description	Component Status
System Off	The system does not have power.	<ul style="list-style-type: none"> • No system status indicator LED on the ADM • No heat • Pump is off
Inactive	The heating system and pumps are disabled.	<ul style="list-style-type: none"> • Yellow system indicator LED on the ADM • No heat • Pump is off
Warm Up	The system is heating the material to the setpoint temperature.	<ul style="list-style-type: none"> • Flashing green system status indicator LED on the ADM • Heat is increasing to setpoint temperature • Pump is off
Heat Soak	Heat zones are all at temperature. Material is soaking for a user specified amount of time.	<ul style="list-style-type: none"> • Flashing green system status indicator LED on the ADM • Heat is at setpoint • Material is absorbing more heat • Pump is off • Heat soak counter counts down on the Home screen.
Ready	All enabled zones are at setpoint temperature. The air motor does not have power.	<ul style="list-style-type: none"> • Flashing green system status indicator LED on the ADM • Heat is at setpoint • Pump is off
Active	The system is ready to dispense.	<ul style="list-style-type: none"> • Solid green system status indicator LED on the ADM • Heat is at setpoint temperature • Pump is on

Overview

A heated platen melts the sealant or adhesive and directs the molten material to the pump inlet. The material then travels through a heated pump and heated fluid moves to the application tool.

Air and Fluid Hoses

The Therm-O-Flow requires Graco single-circuit material hoses rated at a maximum of 1250 watts. Make sure all air and fluid hoses are properly sized for the system.

Heat Control Zone

The Therm-O-Flow has 4, 8, or 12 heat zones. Zones for the heated drum platen and the heated pump are not included in the zone count. Zones 1 and 2, 3 and 4, 5 and 6, 7 and 8, 9 and 10, and 11 and 12 are each available through 12-pin connectors. The heated hoses have a 16-pin connector at the inlet, and an 8-pin connector at the outlet. All heated valves, manifolds, and heaters are equipped with an 8-pin mating connector.

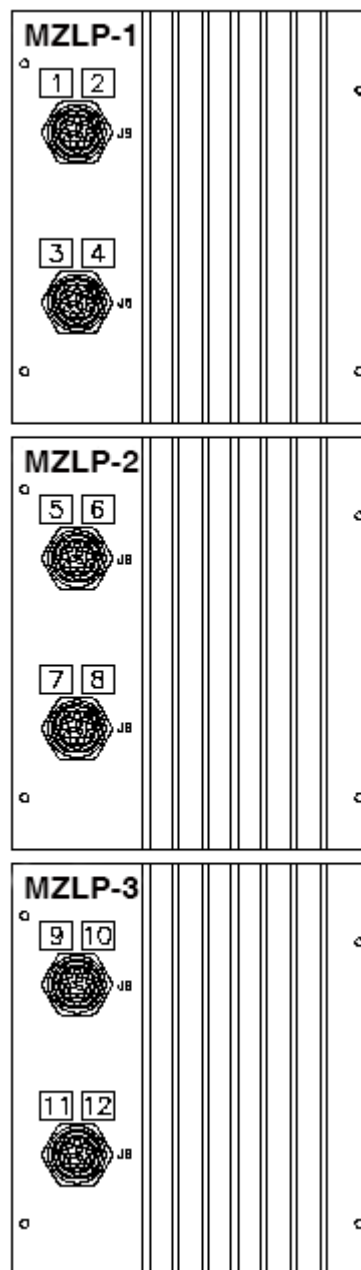

Figure 6 Heat Control Zone Selection

Setup

1. Unpack the ram
2. Locate and Install the ram
3. Mechanical Setup
4. Connect hoses to electrical control panel
5. Connect electrical control panel to power source
6. Ground system
7. Select ADM settings

Unpack

1. Inspect the shipping box carefully for damage. Contact the carrier promptly if there is damage.
2. Open the box and inspect the contents carefully. There should not be any loose or damaged parts in the box.
3. Compare the packing slip against all items in the box. Report any shortages or other inspection problems immediately.
4. Remove the unit from the skid and place it in the desired location. See **Location Requirements**.

Location Requirements

1. Make sure there is sufficient overhead clearance for the pump and ram when the ram is in the fully raised position (approximately 75 in. (190.5 cm).

2. If you are installing a vent hood, make sure there is sufficient horizontal clearance for it. Locate the ram near a connection to the factory ventilation system.
3. Make sure the integrated air controls for the pump and ram are fully accessible, with room to stand directly in front of the controls and the ADM.
4. Make sure there is easy access to an appropriate electrical power source. The National Electrical Code requires 3 ft (0.9 m) of open space in front of the electrical panel. Comply with all local codes and regulations.
5. When locating the system, do not install closer than 36 in. (914 mm) to vertical surfaces.

Install System

Refer to [Dimensions, page 105](#), for mounting and clearance dimensions.

Follow all [Location Requirements, page 16](#), when selecting a location for the ram.

1. Apply 50 psi download pressure to ram.
2. Wrap the bar with the lifting sling.
3. Lift the system off the pallet using a crane or a forklift and place in desired location.
4. Level the base of the ram, using metal shims.
5. Bolt the ram to the floor, using anchors that are long enough to prevent the unit from tipping.

Mechanical Setup

1. Fill displacement pump wet cup 2/3 full with Graco Throat Seal Liquid (TSL™) for Butyl and PSA materials.

Note

Use IsoGuard Select® (IGS) (part no. 24F516) for PUR or reactive Polyurethane material. IGS is designed to dissolve and suspend the Polyurethane materials. IGS will solidify after a period of time and should be replaced once the solidified lube does not return to liquid form after heating.

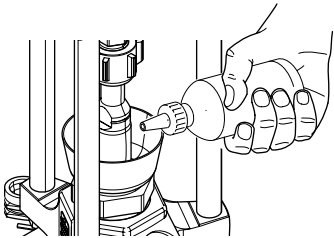

ti24554a

Figure 7 Wetcup

2. Turn all air regulators to their full counterclockwise position. See [Integrated Air Controls, page 9](#).
3. Connect a 1/2 in. (13 mm) air line from an air source to the system air inlet (H), capable of delivering a minimum of 25–50 cfm at 100 psi (0.7 MPa, 7.0 bar). Do not use quick disconnects.

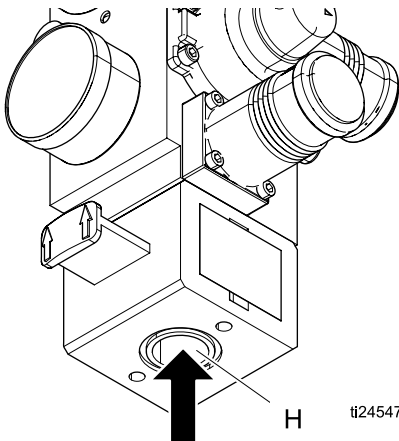

ti24547a

Figure 8 Air Connection

4. Ensure drum low and empty sensors (C) are mounted as shown.

Note

The Drum Low and Empty Sensors are used to indicate that a drum is empty. The kit contains a sensor mounting bracket (A), activator (B), sensors (C1, C2), and a cable for connecting the panel inside the electrical enclosure.

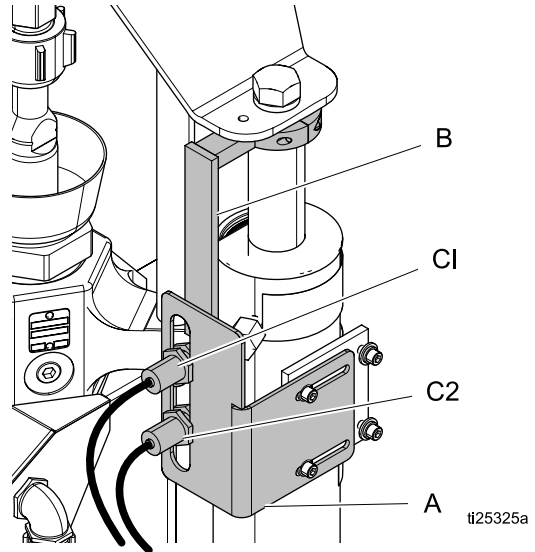

ti25325a

5. Increase the distance between the low (C1) and empty (C2) sensors to increase the heat up time for the tandem secondary system. Lower the empty sensor (C2) to force the heated platen lower into the drum. If empty sensor is set too low, the pump could cavitate and cause an alarm.

Install Heated Hose

To connect a hose to a fluid control device or heated manifold.

1. Install fitting and heated hose onto pump outlet with the large electrical connector side toward the system. Use 2 wrenches to tighten hose. Torque to 45 ft-lbs (61 N•m).

Note

See [Accessories and Kits, page 87](#) , for available fittings and heated hoses.

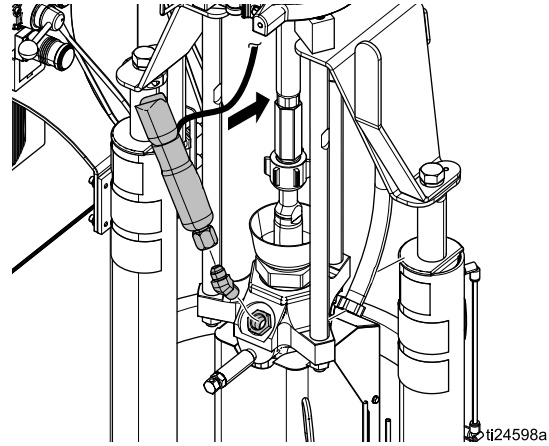

Figure 9

2. Wrap exposed fittings on the pump outlet with Nomex insulation and secure insulation using fiberglass tape.

3. Connect large heated hose connector to adapter cable from MZLP.

Note

All MZLP adapter cables are shipped loose.

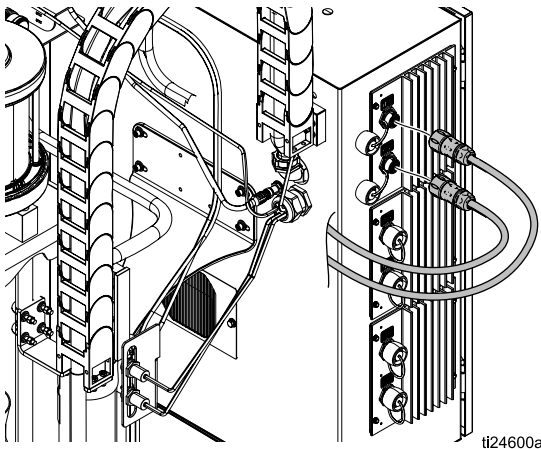
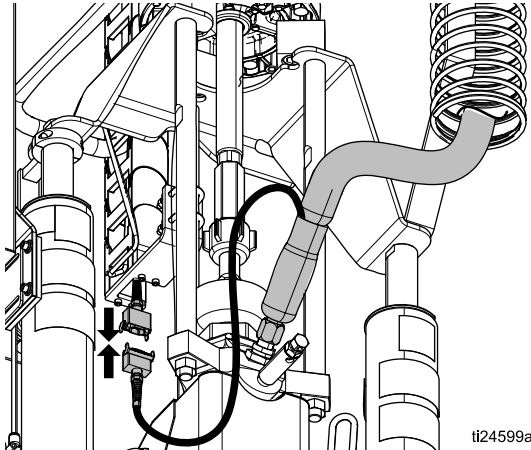

Figure 10

4. Repeat for any remaining channels.
5. Install cap on any unused MZLP electrical connectors.
6. Connect the small 8 pin connector from the heated hose to the fluid control device or heated manifold.

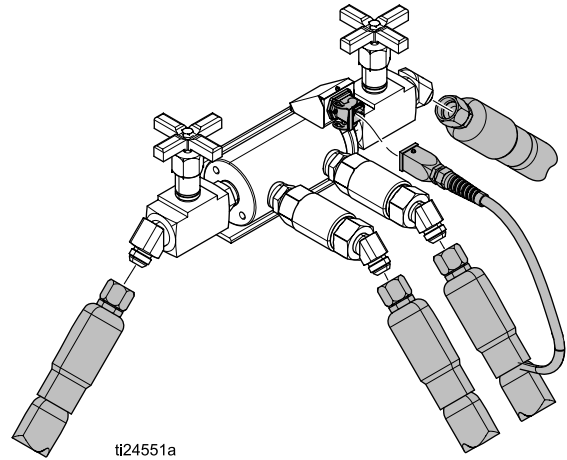

Figure 11 Heated Manifold 243697

Note

The heated manifold (part no. 243697) shown. See [Accessories and Kits, page 87](#) , for available manifolds and fluid control devices.

7. Use 2 wrenches to tighten hose. Torque to 45 ft-lbs (61 N•m).
8. To connect multiple devices, see [Connect Multiple Devices, page 20](#).

Connect Multiple Devices

If your application requires multiple fluid control devices:

- Connect heated hose electrical connections to the electrical enclosure. Use accessory cables if necessary. Additional cables (part no. 17C694) are provided with 8 and 12 zone systems. Remove from shipping box to connect heated hoses to the electrical enclosure. For additional cables, heated hose, and fluid control devices, see [Accessories and Kits, page 87](#).

- Connect fluid control devices to a heated hose or the electrical enclosure. Use accessories if necessary.
- Setup all heat zones on Heat-A and Heat-B screens.

Example: Heated zones used to connect a primary and secondary system to a manifold and two guns. A-# zones are on the Heat-A screen and B-# zones are on the Heat-B screen.

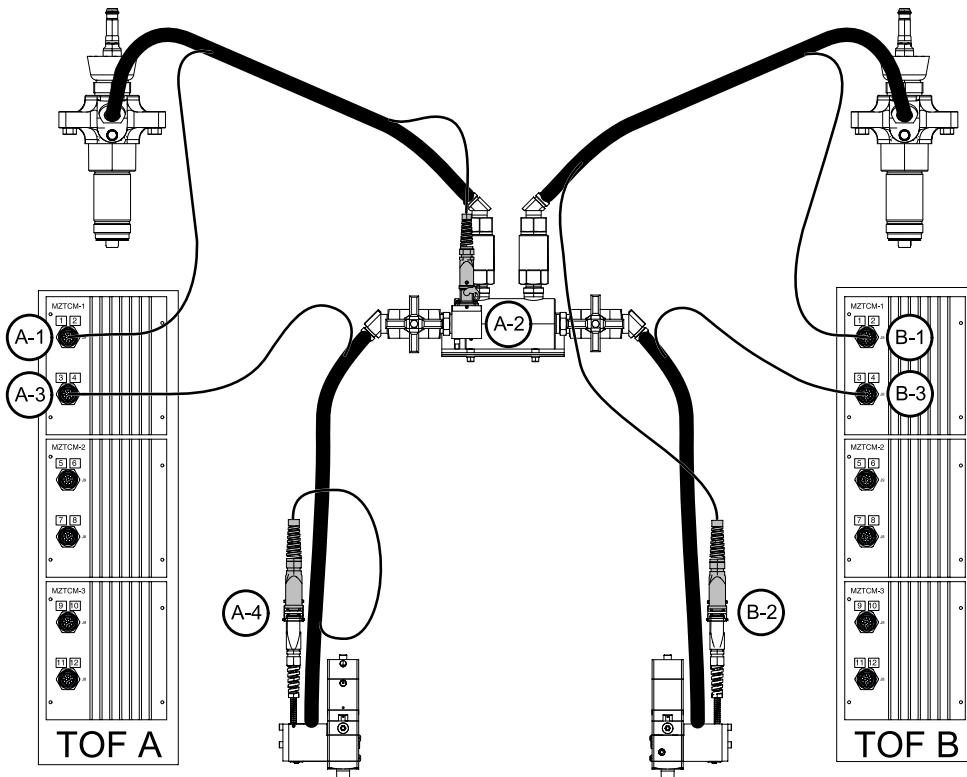
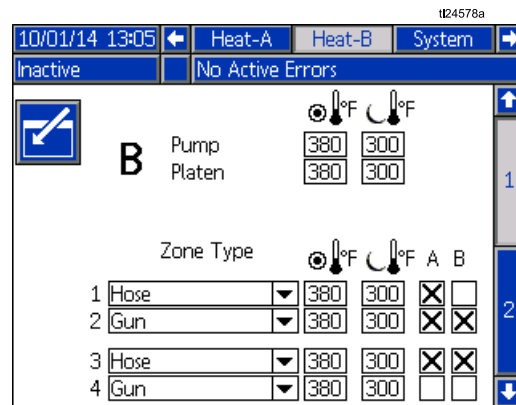
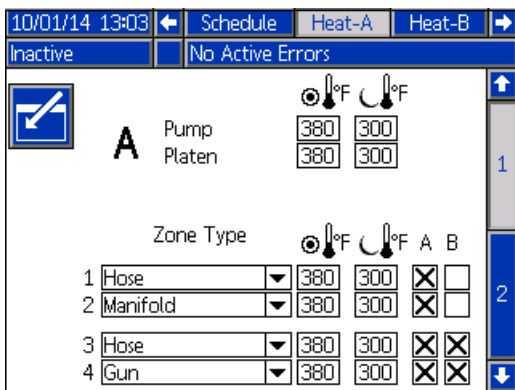

Figure 12



Connect Power

The electrical control panel comes already attached and wired to the ram, however before the supply unit becomes functional you must connect the electrical control panel to a power source.

All electrical wiring must be done by a qualified electrician and comply with all local codes and regulations.					

Note

Required voltage and amperage is noted on the control panel label. Before running power to the unit, make sure the plant electrical service meets the machine's electrical requirements. Branch circuit protection shall be provided by the end user.

Use copper conductors rated 600 volts minimum and 167°F (75°C) minimum only. Torque to 55 in-lb (6.2 N•m).

Table 2 Electrical Requirements

Electrical Panel Voltage	Hz	Phase	Platen	Full Load Amps	AWG
230 V	50/60	3	EF, ES	90	3 AWG
			EM	100	3 AWG
400 V/V/N	50/60	3	EF, ES	90	3 AWG
			EM	100	3 AWG
400 V	50/60	3	EF, ES	45	8AWG
			EM	50	8AWG
480 V	50/60	3	EF, ES	45	8AWG
			EM	50	8AWG
600 V	50/60	3	EF, ES	50	8AWG
		3	EM	50	8AWG

EF Standard Finned Bottom
 EM Mega-Flo
 ES Smooth Bottom

1. Locate the opening in the control panel's top housing for the conduit that will enclose the wire from the facility's power source. The hole will

accept a a cord diameter range of 0.7–1.2 in (17–30 mm).

2. Route the wire from the power source into the control panel housing, and then connect the power source wires to the appropriate terminals on the DISCONNECT switch.

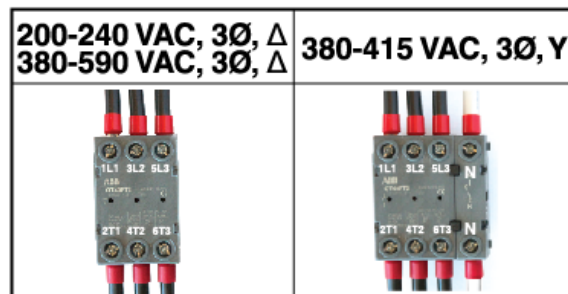

Figure 13

To reduce the risk of fire, explosion, or electric shock, the resistance between the supply unit components and true earth ground must be less than 0.25 ohms.				

3. Connect the ground wire to the ground lug. Have a qualified electrician check the resistance between each Therm-O-Flow system ground and the true earth ground. The resistance must be less than 0.25 ohms. If the resistance is greater than 0.25 ohms a different ground site may be required. Do not operate the system until the problem is corrected.

Note



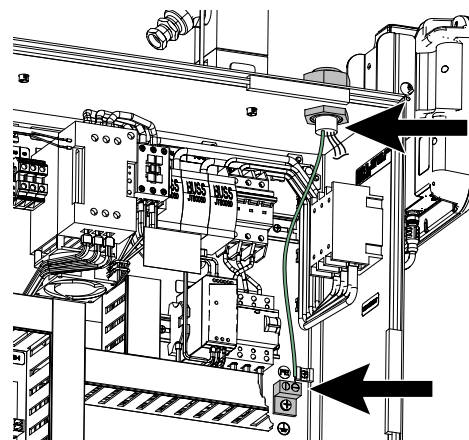

Use a meter that is capable of measuring resistance at this level.



ti24708a

Grounding

Ground the unit as instructed here and in the component manuals.

					
---	---	---	---	--	--

The equipment must be grounded to reduce the risk of static sparking and electric shock. Electric or static sparking can cause fumes to ignite or explode. Improper grounding can cause electric shock. Grounding provides an escape path for the electric current.

System: ground through ground lug in electrical enclosure. See [Connect Power](#).

Air and fluid hoses: use only electrically conductive hoses.

Air compressor: follow manufacturer's recommendations.

Spray gun / Dispense valve: ground through connection to a properly grounded fluid hose and pump.

Material drums: follow local code. Use only metal drums placed on a grounded surface. Do not place the drum on a nonconductive surface, such as paper or cardboard, which interrupts the grounding continuity.

To maintain grounding continuity when flushing or relieving pressure: follow instructions in your separate gun manual for instructions on how to safely ground your gun while flushing.

Connect Secondary System

A secondary system is a Therm-O-Flow supply system that connects to the primary Therm-O-Flow system, with the ADM. See [Models, page 6](#) for secondary system model numbers.

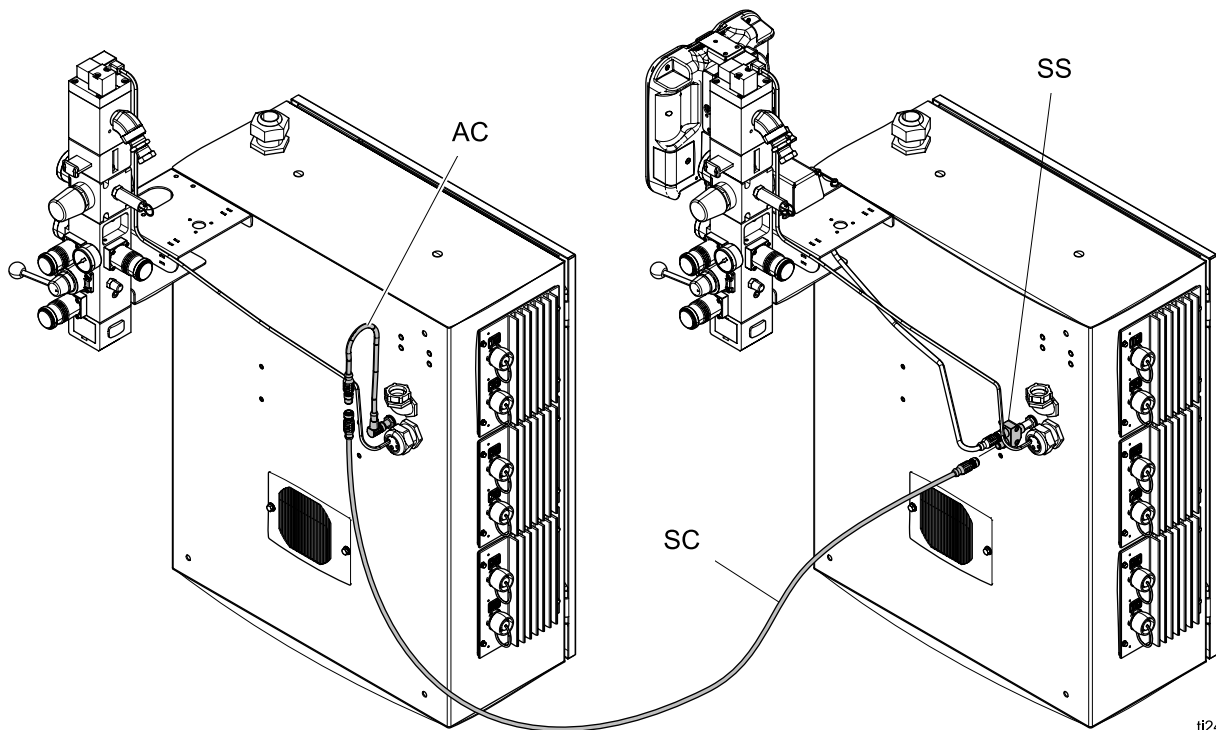

1. Connect adapter cable (AC) and communication cable (SC) to the secondary electrical enclosure and route to splitter (SS) installed on the primary system.
2. To enable a secondary system, select "Enable Tandem System" on the System 1 screen. See [Select ADM Settings, page 25](#).



ti24552a

Figure 14

Check Sensor Resistance

					
To reduce risk of injury or damage to equipment, conduct these electrical checks with the main power switch OFF.					

The package includes up to twelve heat sensors and controllers for each of the heated zones. To check sensor resistance:

1. Turn main power switch off.



2. Wait for components to cool down to ambient room temperature 63°-77°F (17°-25°C). Check electrical resistance for the components.

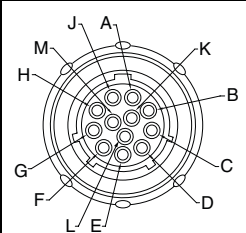

MZLP Zones	Pins	Cable 17C694
First Heat Zone	A,J	
Second Heat Zone	C,D	
First RTD	G, K	
Second RTD	M, K	
Earth Ground	B	

3. Replace any parts whose resistance readings do not comply with the ranges listed in the RTD Sensors chart below.

Table 3 RTD Sensors

MZLP	MZLP Plug	Component	RTD Range (Ohms)
		Ram Plate	100 +/- 2
		Fluid Pump	100 +/- 2
1	1,2	Heated Accessory 1	100 +/- 2
		Heated Accessory 2	100 +/- 2
	3,4	Heated Accessory 3	100 +/- 2
		Heated Accessory 4	100 +/- 2
2	5,6	Heated Accessory 5	100 +/- 2
		Heated Accessory 6	100 +/- 2
	7,8	Heated Accessory 7	100 +/- 2
		Heated Accessory 8	100 +/- 2
3	9,10	Heated Accessory 9	100 +/- 2
		Heated Accessory 10	100 +/- 2
	11,12	Heated Accessory 11	100 +/- 2
		Heated Accessory 12	100 +/- 2

Check Heater Resistance

					
To reduce risk of injury or damage to equipment, conduct these electrical checks with the main power switch OFF.					

2. Make electrical resistance checks for the components.
3. Replace any parts whose resistance readings do not comply with the ranges listed in tables.

Note

Check resistance at ambient room temperature 63°– 77°F (17°– 25°C).

1. Turn main power switch off.



Table 4 Heaters

Component	Between Terminals	For Unit Voltage	Platen Model Code	Resistance Values (ohms)
Platen	FHA1/FHB1 to FHA2/FHB2 (without jumper)	220/240 VAC	EF, ES	14.4Ω +1.5/ -2
	FHA1 to FHA2 or FHB1 (with jumper)	380/590 VAC	EF, ES	28.8Ω +3 / -4
	FHA1 to FHB2 (with jumper)	380/590 VAC	EF, ES	57.6Ω +6 / -8
	Any to GND			100,000Ω Min

Component	Between Terminals	For Unit Voltage	Platen Model Code	Resistance Values (ohms)
Pump	T1/T3 B1/B3	Any	Any	192.0 +/- 19.2Ω

Select ADM Settings

Note

See [Appendix A—ADM, page 94](#) for detailed ADM information, including general operation.

1. Turn main power switch on.



2. When the ADM is finished starting up, press  to switch from the Operation screens to the Setup screens. Use the arrows to navigate between screens.
3. Check system settings on the System 1 screen.

01/26/15 14:38 Heat-A System Advanced
Inactive No Active Errors

External Pump Control:

Enable Diagnostic Screen:

Enable Temp. Adjustments:

Enable Pump Autostart:

Enable Tandem System: Forces Reset

Heat Soak: 45 minutes

Pump Inactive Timeout: 0 minutes

4. Set alarm levels on the System 2 screen.

12/05/14 15:55 Heat-A System Advanced
Inactive No Active Errors

High Temp Alarm Offset: + 40 °F

High Temp Deviation Offset: + 30 °F

Low Temp Deviation Offset: - 30 °F

Low Temp Alarm Offset: - 40 °F

5. Set primary system setpoint and setback temperatures for the pump, platen, and heat zones on the Heat-A screens.

12/05/14 16:09 Schedule Heat-A System
Inactive No Active Errors

A Pump 380 300
Platen 380 300

Zone Type 380 300 A

1	Hose	380	300	<input type="checkbox"/>
2	Gun	380	300	<input type="checkbox"/>
3	Hose	380	300	<input type="checkbox"/>
4	Gun	380	300	<input type="checkbox"/>

Note

Setback temperatures must be at least 20°F (10°C) lower than the setpoint temperatures

Note

To ensure accurate hose temperatures, be sure all heated hoses have their “zone type” set to “Hose.” Hoses are only present on odd zone numbers: 1, 3, 5, 7, 9, or 11.

- a. Select the appropriate “Zone Type” for all installed zones.
 - b. Check the “A” and “B” boxes according to which systems needs to use the heated accessory.
6. If a secondary system is used, set temperatures on the Heat-B screens.
 7. Set the system date and time on the Advanced 1 screen.

12/05/14 15:57 Advanced Maintenance - A
Inactive No Active Errors

Language: English

Date Format: mm/dd/yy

Date: 12 / 05 / 14

Time: 15 : 57

Enter Password: 0000

Screen Saver: 6 minutes

Silent Mode:

Setup

- Set the temperature and mass units on the Advanced 2 screen. Set the specific gravity of the material for Material Tracking functionality.

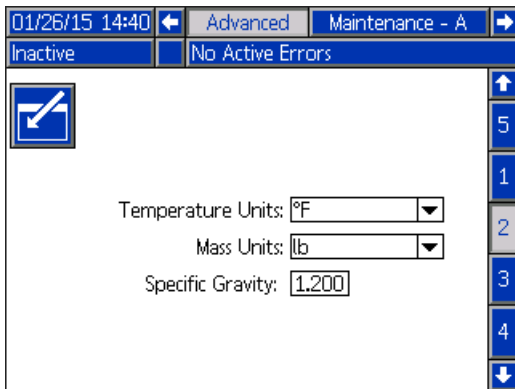

The screenshot shows a control panel interface. At the top, there is a status bar with the date and time '01/26/15 14:40', a left arrow, the text 'Advanced', 'Maintenance - A', and a right arrow. Below this, there are two status indicators: 'Inactive' and 'No Active Errors'. The main area contains three settings: 'Temperature Units' with a dropdown menu showing '°F', 'Mass Units' with a dropdown menu showing 'lb', and 'Specific Gravity' with a text input field containing '1.200'. On the right side of the main area, there is a vertical navigation bar with buttons labeled '5', '1', '2', '3', '4', and a down arrow.

Note

If the Specific Gravity is set to zero, the Home screen will display a cycle counter instead of grams or pounds.

- To setup the optional Schedule function, see [Schedule, page 37](#).

The schedule function allows the system to automatically enable and disable heating and setback at specified times.

- Optional: Set any remaining settings in the Setup screens before using the system. These are not required for system operation, but include useful functions. See [Appendix A—ADM, page 94](#) for detailed information about each setup item.

Connect PLC

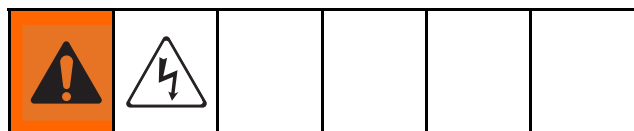

A PLC can control and monitor all items shown in the Customer Digital Inputs and Outputs shown on the Diagnostics screen. See [Appendix A— ADM, page 94](#).

When the PLC has control of the system:

- Functionality is restricted from the ADM
- Automatic crossover is disabled. Rely on the PLC and machine state indicators to know when to cross over using the I/O.

Table 5 Customer Input

Signal No.	Unit A	Description
1	Heat On Request	Turn on the Heat
2	Setback Request	Put the Unit in Setback
3	Pump On Request	Turn on the Pump
4	PLC Control Request (input applies to primary to unit A only)	Control the primary and secondary TOF systems from the PLC instead of the ADM

Table 6 Customer Output

Signal No.	Unit A or B	Description
1	Run State Bit Low	See Run State Chart
2	Run State Bit High	See Run State Chart
3	Error State Bit Low	See Error State Chart
4	Error State Bit High	See Error State Chart

Table 7 Output Error States

Error State Bit High	Error State Bit Low	
0	0	Machine is good, no errors are present
0	1	Active Unit Drum Low
1	0	Active Unit Drum Empty
1	1	Alarm Present in System

Table 8 Output Run States

Run State Bit High	Run State Bit Low	
0	0	Pump Off/ Heat Off
0	1	Pump Off/ Heat On
1	0	Pump Off/ Heat At Temp
1	1	Pump On/ Heat At Temp

Note

All outputs are normally open when power is OFF. For error (alarm) output, the contacts close when an alarm occurs. For all others, contacts close.

Note

The TOF system ships with two screw terminal connectors that plug into MZLP connectors H1 and H2. Connectors are located in a bag on the inside of the electrical enclosure. To replace the connectors, order kit 24P176.

1. Turn main power switch off.
2. Open the electrical enclosure door.
3. Route I/O cables through strain relief.
4. Remove power from the PLC.
5. Connect the PLC to connectors H1 and H2.

Note

Each connector has four signals. The MZLP board specifies the input range for each signal. See the following table for pin assignments.

Setup

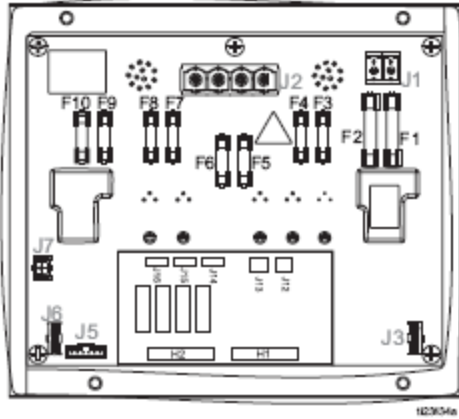

Figure 15

H1 Customer Input	
Signal	Pin
1	1,2
2	3,4
3	5,6
4	7,8

H2 Customer Output	
Signal	Pin
1	1,2
2	3,4
3	5,6
4	7,8

Inputs: High: 10–30 VDC, Low: 0–5 VDC. Inputs function without concern for polarity. Applying “high” voltage will turn the heaters on and enable setback. Removing voltage will turn the heaters off and disable setback.

Outputs: 0–250 VAC, 0–30 VDC, 2A Maximum.

PLC Connections Block Diagrams

The following block diagrams show how to connect customer inputs and outputs to the MZLP. For convenience, each system ships with connector kit 24P176. If a connector is lost or damaged, order kit 24P176 for replacements.

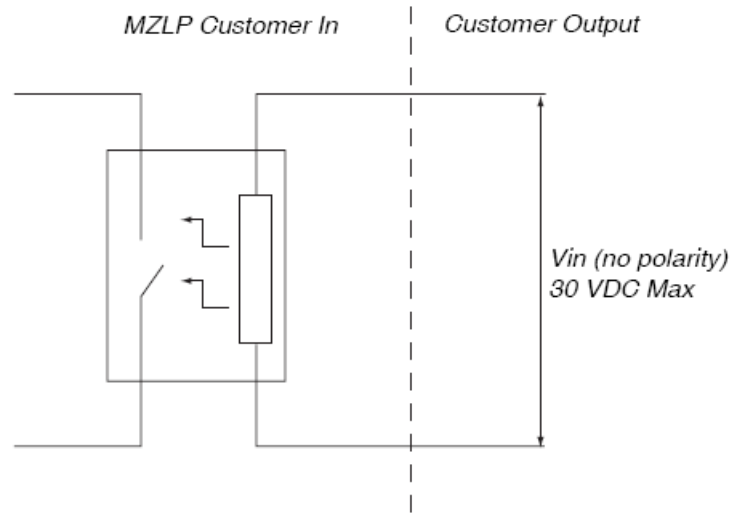

Figure 16 Customer Input

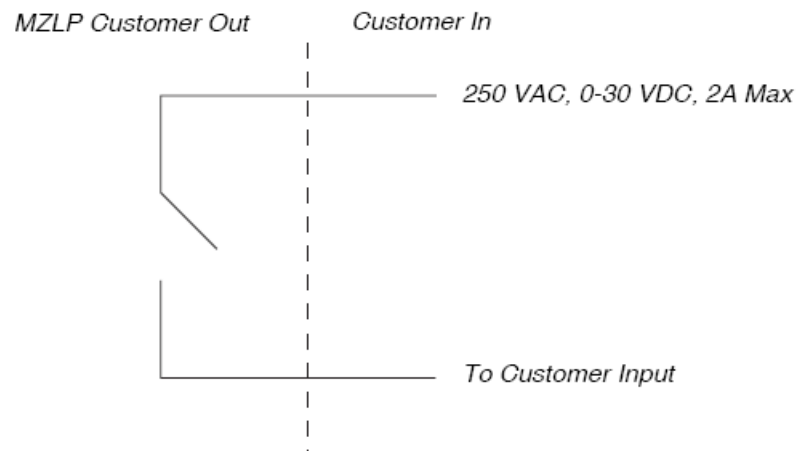



Figure 17 Customer Output

Operation

1. Turn the main power switch ON. The Graco logo will display until communication and initialization is complete.



2. Press the  button. Verify the machine is in "Warm Up" state, and that the temperatures are increasing. Allow the system to reach the "Ready" state before pumping. The pump will automatically turn on, if autostart is enabled in setup screens, when all the heat zones reach their setpoint temperature.

Purge System



NOTICE

Purge the system before initial use and when chemicals are changed to prevent material contamination, which may cause the material to fail or perform poorly. The system was factory-tested using a light soluble oil, a soybean oil, or some other oil as tagged. Flush the system to avoid contaminating the material that has been designated for initial material loading.

NOTICE

Use fluids that are chemically compatible with the equipment wetted parts. See Technical Specifications in all of the equipment manuals.

1. Select the material for the initial material load.
2. Verify whether the factory-test oil and the initial material load are compatible:
 - a. If the two substances are compatible omit the remaining steps in this procedure and refer to the [Load Material, page 31](#).
 - b. If the two substances are incompatible perform the remaining steps in this procedure to flush the system.
3. Select a pail of material that can eliminate the factory-test oil from the system. If necessary, check with Graco or the material supplier for a recommended solvent.
4. Before purging be sure the entire system and waste pail are properly grounded. See [Grounding, page 22](#).
5. Turn all heat zones' setpoint temperature to the material manufacturer's recommended dispense temperature, or a minimum of 100°F (37°C) minimum.

Note

Remove any dispense valve orifices before purging. Reinstall after purging has been completed.

6. Purge the material through the system for approximately 1 to 2 minutes.
7. Remove the pail if purge material was used. See [Change Pail, page 38](#).

Load Material

NOTICE

To prevent damage to platen wipers, do not use a pail of material that has been dented or damaged. An empty pail clamp can interfere with up and down operation of the ram. When raising the ram, make sure the pail clamp stays clear of the platen.

Note

Before loading material, make sure there is a minimum overhead clearance of 75 in. (191 cm) and all air regulators are backed off to their full counterclockwise position.

1. Open the main air slider valve (CA).

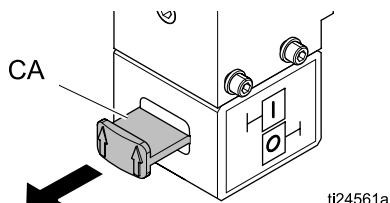

2. Set ram director valve (CC) to UP and slowly turn the ram up regulator (CD) clockwise until the platen (G) begins to rise.

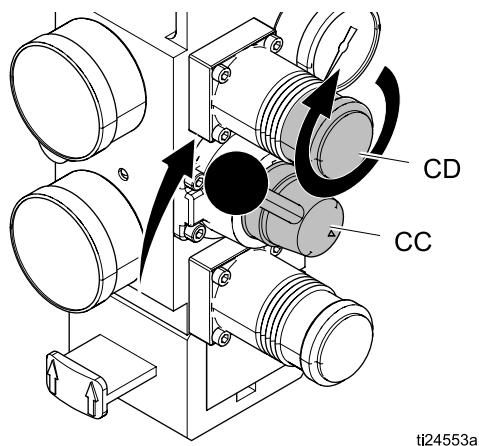

Figure 18 Raise the Platen

3. Apply a thin coating of high temperature grease lubricant (part no. 115982) to the platen pail seals.

4. Fill displacement pump wet cup 2/3 full with Graco Throat Seal Liquid (TSL™) for Butyl and PSA materials.

Note

Use IsoGuard Select® (IGS) (part no. 24F516) for PUR or reactive Polyurethane material. IGS is designed to dissolve and suspend the Polyurethane materials. IGS will solidify after a period of time and should be replaced once the solidified lube does not return to liquid form after heating.

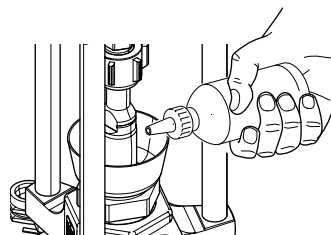

Figure 19 Wetcup

5. Open pail, remove any packing material, and inspect material for any contamination.
6. Slide the pail against the stops at the back of the ram baseplate.

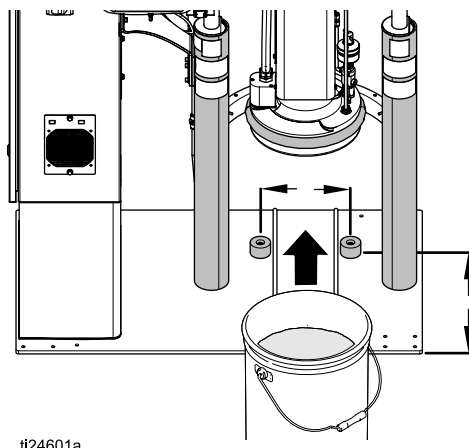

Figure 20 Drum Placement

Operation

- Remove the platen bleed stick (R).

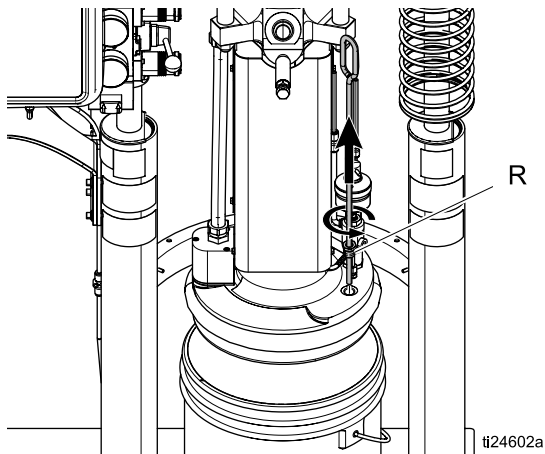

Figure 21 Platen Bleed Handle

- Set ram director valve (CC) to down and lower the platen.

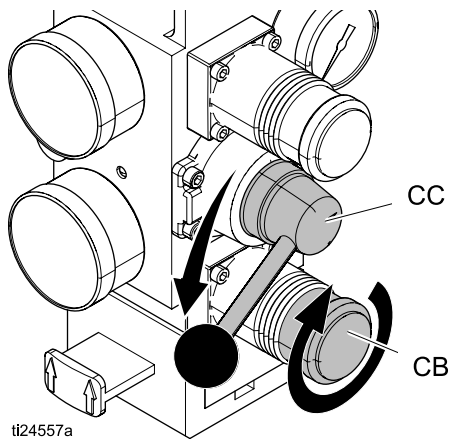
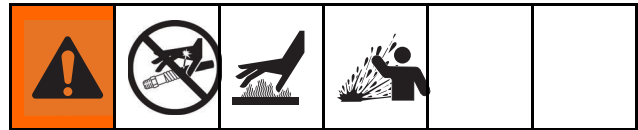

Figure 22 Lower the Platen

- Slowly turn the ram down air regulator (CB) clockwise to approximately 5–10 psi (34–69 kPa, 0.3–0.7 bar). The platen will begin to lower into the pail.
- After the platen seals enter the material pail, adjust the ram down air regulator (CB) to 30–50 psi (207–345 kPa, 2.1–3.4 bar).
- When the ram stops, reinsert the platen bleed stick (R) and hand tighten.

Heat Up System



To reduce the risk of bursting a hose, never pressurize a hot melt system before turning on the heat. The air will be locked from the air motor until all temperature zones are within a preset window of the temperature setpoints.



Keep the dispense valve open over a waste container while the system is heating up and also when cooling down. This will prevent a pressure build-up caused by fluids or gases expanding from the heat.

Note

Operate at the lowest temperature and pressure necessary for your application.

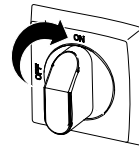
- Turn the main power switch on the electrical control panel door to the ON position.



- Press the  button. The zones begin to heat (provided they are enabled). Press  if the zones do not begin to heat. Display status bar reads **Warm Up**. When temperature reaches setpoint, the display status bar reads **Heat Soak**. When heat is on, the status will display in the status bar. See [Advanced Display Module \(ADM\), page 12](#), for operation mode descriptions.

Note

The air will be locked from the air motor until all temperature zones are within a preset window of the temperature set points, allowing the system to heat fully and complete the material heat soak period.

Prime Pump



1. Ensure that the system has completed the heat soak cycle. The display status bar should read **Active**.
2. Adjust the air motor air regulator (CK) to 0 psi.

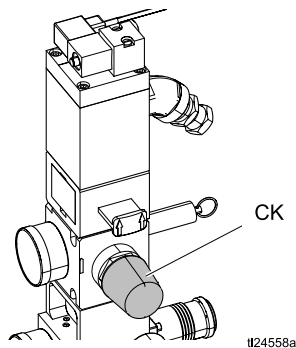

3. Ensure air motor solenoid valve (CN) is on. The indicator light on the solenoid connector will only be on if "Enable Pump Autostart" is selected on the System 1 Setup screen.

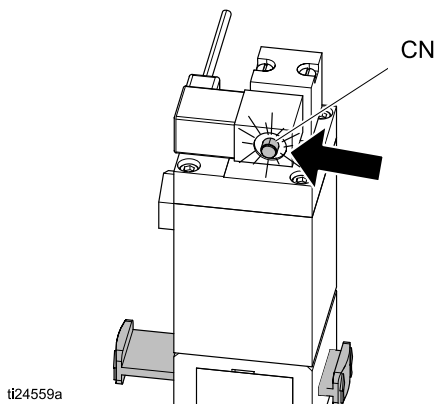

4. Adjust the air motor slider valve (CM) to the open position.

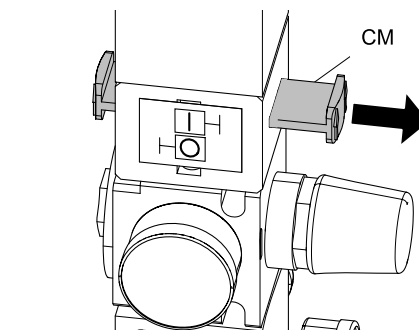

5. Adjust the air motor air regulator (CK) to approximately 20 psi (138 kPa, 1.38 bar).

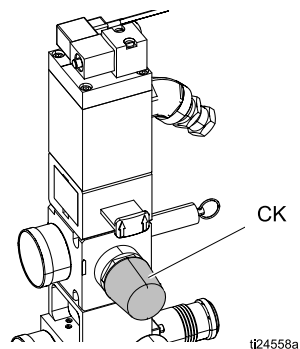

6. Place a waste container under the bleed stem (Z). Using an adjustable wrench, open the bleed stem counterclockwise 1/3 - 1/2 turn.

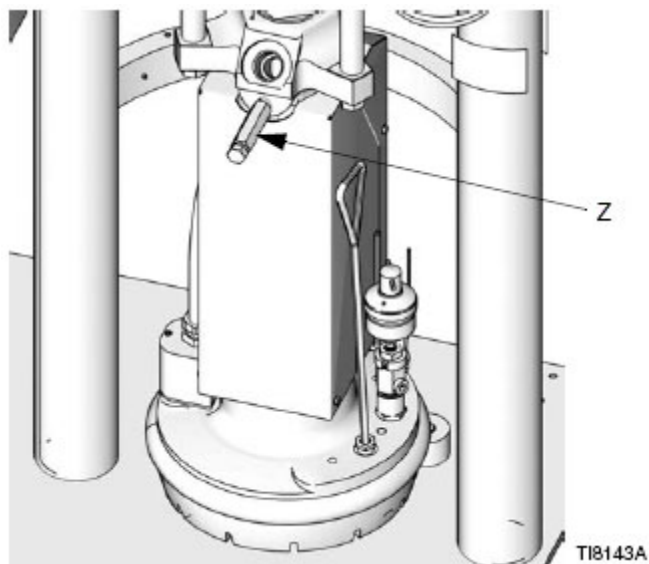

Operation

7. If a new pail was installed and the unit is equipped with proximity sensors, press the Pump Ready button . Press pause button on material tracking.
8. Adjust the air motor air regulator (CK) up by 5 psi (34 kPa, 0.3 bar). Never adjust the regulator by more than 5 psi (34 kPa, 0.3 bar) increments. Make sure the pump begins to cycle and heated material flows from the bleed stem (Z) after several cycles of the pump.
9. Prime the pump until it moves smoothly in both directions with no air popping or erratic movement and close the main air slider valve (CA).

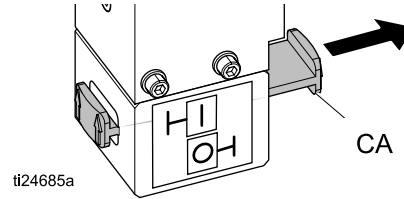

10. Close the bleed stem (Z).
11. Press Play button on home screen to enable material tracking.

Prime System



1. Close the main air slider valve (CA).

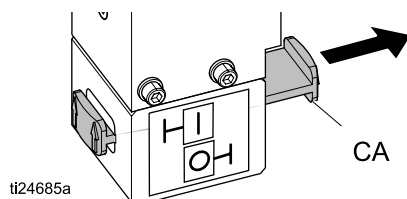

2. If using a manual gun, lock the dispense valve trigger open by pulling and securing the trigger using the trigger retainer (Z).

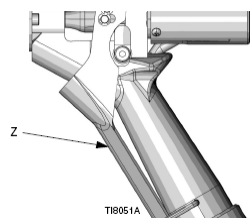

3. Place the dispense valve over a waste container.
4. Press the pause material tracking button  on home screen.
5. Slowly open the main air slider valve (CA).
6. Prime the system until a smooth flow of material dispenses from each dispense valve.

Note

On initial system startup, the pump will cycle until the hoses are filled. If a new drum was placed on the frame, the pump will cycle until all air has been removed.

7. Close the main air slider valve (CA) and release trigger lock.
8. Engage trigger lock.

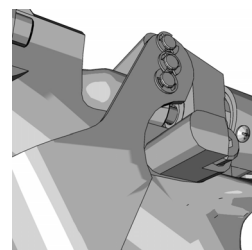



Figure 23 Trigger Lock Engaged

9. Press  to engage material tracking.
10. Turn the air motor regulator to operating pressure.

Note

The system is now ready to operate.

Setback Mode

Set the ADM to setback mode if the system will only be inactive for a few hours. This will reduce the time system needs to return to setpoint temperatures.

1. Press  to enter Setback Mode.

Note

The amount of time before the pump is automatically placed in setback is determined by the Pump Inactivity Timeout, located on System Setup Screen 1. See [Setup Screens, page 97](#).

Pressure Relief Procedure



Follow the Pressure Relief Procedure whenever you see this symbol.



This equipment stays pressurized until pressure is manually relieved. To help prevent serious injury from pressurized fluid, such as skin injection, splashing fluid and moving parts, follow the Pressure Relief Procedure when you stop spraying and before cleaning, checking, or servicing equipment.

Note

If using a different dispense applicator, see the applicator manual for pressure relief instructions.

1. Engage the trigger lock.

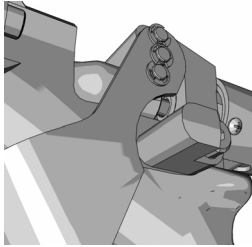
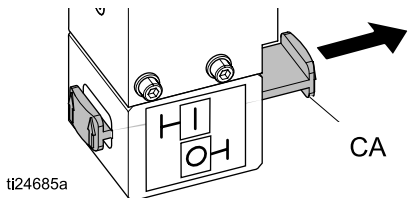
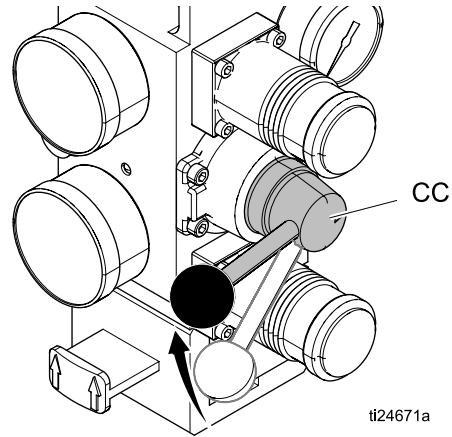

Figure 24 Engaged

2. Close the system master air slider valve (CA).



3. Set the ram director valve (CC) to the neutral position.



4. Disengage the trigger lock.

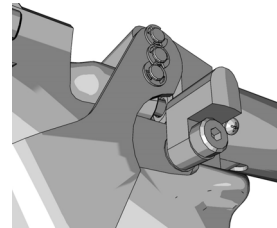

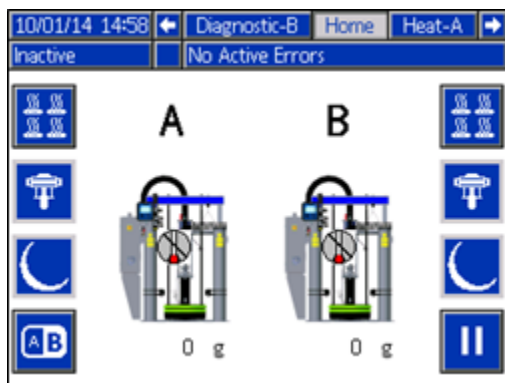

Figure 25 Disengaged

5. Hold a metal part of the gun firmly to a grounded metal pail. Trigger the gun to relieve pressure.
6. Engage the trigger lock.
7. Open all fluid drain valves in the system, having a waste container ready to catch drainage. Leave drain valve(s) open until you are ready to dispense again.
8. If you suspect the tip or hose is clogged or that pressure has not been fully relieved after following the steps above, **VERY SLOWLY** loosen hose end coupling to relieve pressure gradually, then loosen completely. Clear hose or tip obstruction.

Shutdown

- Press  to disable the heaters and pump. The screen will say "Inactive". If using the Schedule function, the heaters and pump will be disabled automatically at the set time. Only press  to disable the heating system before the set time. If the heaters were manually disabled, the Schedule function will automatically enable them at the next set time.



Note

Do not perform step 2 if using the Schedule function. Leave the power on.

- Turn main power switch off.

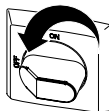

Schedule

The Schedule function allows the user to specify times when the system will automatically turn ON and OFF the heaters and pump.

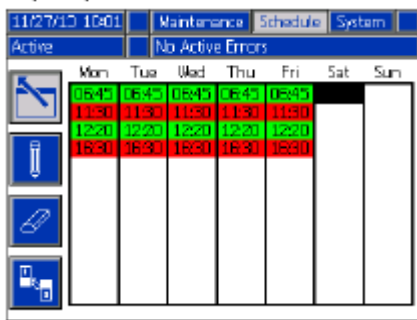
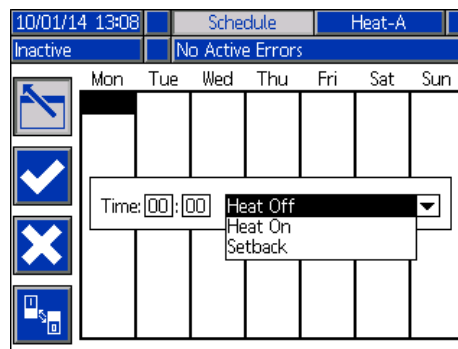

Table 9 Schedule Screen Color Identification

Color	Description
Green	System on
Yellow	Setback
Red	System off
Gray	Disabled

Set Schedule Times

Times are set using a 24-hour clock. Several on and off times can be set each day.



- On the Schedule screen (in the Setup screens), set the ON times for each day of the week.
- Set the OFF times for each day of the week.
- Set the setback times for each day of the week.

Enable Schedule Function

The Schedule function is automatically enabled when values are entered in the Schedule screen. To disable a scheduled event, navigate to the event and



press

The event will appear gray on the screen when it is disabled. To re-enable an event, navigate to the

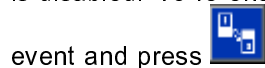

event and press

The event will appear red (system off), yellow (system setback), or green (system on). If no events are needed, turn the main power switch OFF to prevent system from automatically enabling and disabling the heaters.

Use the Schedule Function

At the end of the work day leave the main power switch ON. The Schedule function will automatically enable and disable the heaters and pump at the specified times.

Change Pail

<p>To prevent serious burns from dripping material, never reach under the heated platen after the platen is out of the pail.</p>				

Follow the procedure to change the pail on a fully heated system.

NOTICE	
<p>Be sure to reload the empty supply unit with a full pail of material immediately. Do not raise the ram and remove the platen from the empty pail until you are ready to immediately install a new pail.</p> <p>Do not raise the ram and remove the platen from the empty pail unless the supply unit is at full operating temperature. Drum changes can only be performed when the system is heated.</p> <p>An empty pail clamp can interfere with the up and down operation of the ram. When raising or lowering the ram, make sure the pail clamp stays clear of the platen assembly.</p> <p>Do not use a pail of material that has been dented or otherwise damaged; damage to the platen wipers can result.</p>	

All systems include Low/Empty Sensors:

- The air will shutoff to prevent the pump from cavitation. If the light tower kit is installed, a solid red light indicates that the pail is empty and ready to change.
- In a tandem system, a flashing red light means that both drums are empty and the system has shutdown.

1. Press  to stop material tracking.
2. Push in the air motor slider valve (CM) to stop the pump.

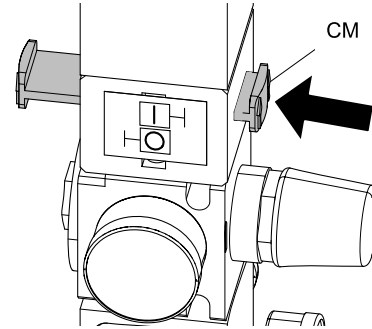

t24560a

3. Set ram director valve (CC) to UP and raise the platen (G) and immediately press and hold the blowoff buttons (CG) until the platen is completely out of the pail. Use minimum amount of air pressure necessary to push the platen out of the pail.

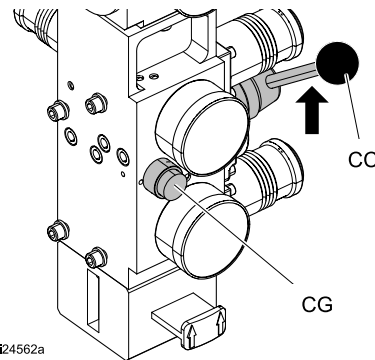

t24562a

<p>Excessive air pressure in the material pail could cause the pail to rupture, causing serious injury. The platen must be free to move out of the pail. Never use pail blowoff air with a damaged pail.</p>				

4. Release the blowoff air button and allow the ram to rise to its full height.
5. Remove the empty pail.
6. Inspect platen and if necessary, remove any remaining material or material build-up.
7. Follow steps in [Load Material, page 31](#), and [Prime Pump, page 33](#).

Troubleshooting

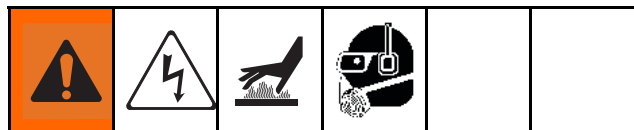



Light Tower (Optional)

Signal	Description
Red Light Off	If green light is also off, system power may be off or system operating mode is inactive. If green is on or flashing, there are no active errors.
Red Light On	User interaction required — alarm, system is shut down
Red Light Flashing	User interaction required — advisory, deviation, or system is in a state that could prohibit dispensing.
Green Light Off	System is inactive
Green Light On	System is ready to dispense. The heat and pump are on.
Green Light Flashing	System will be ready to dispense in time without user interaction (heat on, pump off, and temperature control zones have not reached set point)

Error Codes

There are three types of errors that can occur. Errors are indicated on the display as well as by the optional light tower.

Alarms are indicated by . This condition indicates a parameter critical to the process has reached a level requiring the system to stop. The alarm needs to be addressed immediately.

Deviations are indicated by . This condition indicates a parameter critical to the process has reached a level requiring attention, but not sufficient enough to stop the system at this time.

Advisories are indicated by . This condition indicates a parameter that is not immediately critical to the process. The advisory needs attention to prevent more serious issues in the future.

To acknowledge the error, press .

The third digit, or sometimes the last digit of the error code, indicates which unit the error is active on. The “★” (star) character indicates the code applies to multiple system components.

Third or Last Digit “★”	Codes Relates To:
A	Unit A
B	Unit B

The last digit of the error code indicates which system component the error applies. The “#” (pound) character indicates the code applies to multiple system components.

Last Digit “#”	Codes Relates To System Component:
1	MZLP 1
2	MZLP 2
3	MZLP 3
5	MZLP 5
6	MZLP 6
7	MZLP 7
V	AWB Unit A
W	AWB Unit B
X	Daughter Board Unit A
Y	Daughter Board Unit B

The last digit of the error code indicates which heat zone the error applies. The “_” (underscore) character indicates the code applies to multiple system components.

Last Digit “_”	Codes Relates To Heat Zone:
1	Zone 1
2	Zone 2
3	Zone 3
4	Zone 4
5	Zone 5
6	Zone 6
7	Zone 7
8	Zone 8
9	Zone 9
A	Zone 10
B	Zone 11
C	Zone 12
D	Pump
E	Platen

Code	Description	Type	Cause	Solution
A3MF	AWB Clean Fan Filter	Alarm	Cooling inlet screen is dirty	Clean inlet screen.
A4★_	High Current Unit _ Zone _	Alarm	Defective or shorted to ground on zone	Verify accessory is rated for 240 VAC. Verify heater resistance and check for shorts to ground. Replace as necessary.
A4C#	High Current Fan AWB, Unit _	Deviation	Fan is drawing too much current	Verify there is not an air obstruction at the inlet/outlet of enclosure. verify nothing is preventing fan rotation. Replace fan if necessary.
A7★_	Unexp. Curr. Unit _ Zone _	Alarm	Unexpected current flow to zone	Replace MZLP. Faulty accessory heater. Measure resistance to ground between heater leads.
A8★_	No Current Unit _ Zone _	Alarm	No Current Flow to the Zone	Check for loose or disconnected wires or plugs. Check for blown fuses on MZLP. Check heater resistance for open circuit. Check for shorts between heater and ground. Verify cable is plugged into zones 3–4. Replace heater if necessary.
A8C★	AWB No Fan Current	Alarm	Cooling fan not working	Verify fan is plugged in. Replace if necessary.
AM3 #	High Current SSR MZLP _	Alarm	Excessive current flow in the SSR	Check for shorts in harness to SSR. Check polarity of wiring to SSR. Replace if necessary.
AM4 #	High Current Contactor MZLP _	Alarm	Defective or shorted to ground on MZLP	Check for shorts in the harness to contactor. Check the polarity to contactor. Replace contactor if necessary.
AM8#	No Current Contactor MZLP _	Alarm	No Current Flow to the Contactor	Ensure harness to MZLP is connected. Ensure wiring to contactor is secure. Replace contactor if necessary.
CAC#	Comm Error MZLP _	Alarm	System not responding to ADM.	System is not properly loaded with correct Software. Dial not set correct on MZLP. Duplicate MZLP dial positions (i.e. 1 to 1, 2 to 2, ect) Check all CAN connections between the ADM and missing MZLP. Check if hardware exists on the network. Replace MZLP if necessary.
CACX	DB Not Present Unit A	Alarm	Daughter Board not responding	Dial not set correct on MZLP 5. Set to 5 on board with daughter board. Ensure connections between the ADM and hardware are secure. Replace Daughter Board.
CACY	DB Not Present Unit B	Alarm	Daughter Board not responding	Dial not set correct on MZLP . Set to 4 on board with daughter board. Ensure connections between the ADM and hardware are secure. Replace Daughter Board.

Troubleshooting

Code	Description	Type	Cause	Solution
CACV	AWB not present Unit A	Alarm	AWB not responding	Ensure connections between the ADM and hardware are secure.
				If a tandem system, ensure AWB 2 jumper is installed at startup.
				Replace AWB.
CACW	AWB not present Unit B	Alarm	AWB not responding	AWB 2 jumper was not in place at start up
				Ensure connections between the ADM and hardware are secure.
				Replace AWB.
DA★X	Pump Runaway Detected	Alarm	Pump is trying to feed adhesive, no adhesive to feed.	Adjust the drum empty level sensor to detect an empty state.
				Ensure the ram director valve is in the down position and sufficient air is forcing the ram down.
				Melter at incorrect temperature, too low. Check setpoint and set to manufactures recommendation.
			Worn or damaged pump seals	Inspect pump seals and replace if necessary
DE★X	Reed Switch Failure Detected	Alarm	Reed switch failed	Check that sensor cable is plugged into the daughter board at J16.
				Check for loose connection at reed switch. Ensure reed switch is securely attached to the air motor. Replace if necessary.
DC★X	Pump Diving	Alarm	Pump is trying to feed adhesive, no adhesive to feed.	Adjust the drum empty level sensor to detect an empty state.
				Ensure the ram director valve is in the down position and sufficient air is forcing the ram down.
				Melter at incorrect temperature, too low. Check setpoint and set to manufactures recommendation.
			Worn or damaged pump seals	Inspect pump seals and replace if necessary
L1★X	Material Level Sensor Error	Alarm	Machine is detecting an empty state without a low state	Make sure the empty level sensor is not covered in material
				Verify the low level sensor is plugged into J15 of the daughter board. Verify the low level sensor is close enough to the metal bar; adjust if necessary.
				Replace sensors.
L2★X	Material Level Empty	Alarm	Material drum is empty	Replace material container. If more material is leftover, lower the empty level sensor.
L3★X	Material Level Low	Deviation	Material level is low	Replace at appropriate time.
MMUX	USB Log Full	Advisory	USB logs fulls. Data loss will occur if not downloaded.	Download USB data or disable the USB log errors on the Advanced screen 3.
MN★X	Pump _ Requires Maintenance	Advisory	User defined pump maintenance counter has run out	Perform pump maintenance, then reset the counter on the maintenance setup screen.

Code	Description	Type	Cause	Solution
T1★ _ _ Zone _		Alarm	Zone temperature too low	Reduce flow rate.
				Increase temperature of accessory upstream.
				Faulty accessory heater measure resistance between heater leads.
				Change Low Temp Alarm Offset.
T2★_ _ Zone _		Deviation	Zone temperature too low	Reduce flow rate.
				Change Low Temp Deviation Offset.
				Add zone (temperature) upstream.
T3★ _ Unit _ Zone _		Deviation	Temperature reading has risen too high	Change High Temp Deviation Offset.
				Verify setpoint upstream is not hotter than this zone's setpoint.
T4C#	AWB Temperature Runaway Transformer	Alarm	Cooling fan not working or inlet is blocked/dirty	Ensure inlet and outlets are not obstructed.
				Verify fan is plugged in.
T4M#	AWB High Transformer Temp	Alarm	Transformer Temperature is too High	Ensure inlet and outlets are not obstructed.
				Verify fan is plugged in.
T4★_ Unit _ Zone _		Alarm	Temperature reading has risen too high	Change High Temp Alarm Offset.
				Verify setpoint upstream is not hotter than this zone's setpoint.
T6★ _ _ Zone _	Sensor Err. Unit	Alarm	Bad RTD Reading	Check RTD wiring and harness/connector integrity.
				Replace RTD.
T6C#	AWB Invalid Thermistor Reading	Alarm	Transformer thermistor temperature is incorrect	Verify thermistor is securely connected to J7 of the AWB. Replace transformer if necessary.
T8V _ Unit _ Zone _	No Temp. Rise	Alarm	Temperature reading does not change.	Check fuses on MZLP connected to that Zone.
				Check wiring to device.
				Check heater resistance on device.
V1#	Low CAN Voltage, MZLP	Alarm	Bad or overloaded power supply	Verify power supply voltage is 24 VDC. If voltage is low, disconnect the power lines and re-check voltage reading. If voltage is still low, replace power supply. If voltage is correct after disconnecting the power lines. Connect items one at a time until the voltage drops to isolate the bad module.
V1M#	Low Voltage Line AWB, Unit	Deviation	The voltage to the AWB is below threshold	Verify transformer voltage top matches incoming voltage. Verify incoming voltage is correct.
V4#	High CAN Voltage, MZLP	Alarm	Bad or overloaded power supply	Verify power supply voltage is 24 VDC. If voltage is high, replace power supply unit.

Troubleshooting

Code	Description	Type	Cause	Solution
V6M#	Wiring Error Line MZLP _	Alarm	Incoming power is wired incorrectly	Correct the Wiring.
V8M#	No Line Voltage MZLP _	Alarm	Incoming line voltage is less than 100 VAC.	<p>Verify transformer has the correct tap selected.</p> <p>Verify CB-1 or FU-4, FU-5, and FU-6 are not tripped/blown.</p> <p>Verify RCD-1 is not tripped.</p> <p>Measure incoming power with system unplugged. If line voltage is less than 100 VAC, contact qualified electrician to correct the low voltage.</p> <p>Verify the MZLP is plugged in at J2 and the AWB is plugged in at J5 and J6.</p>
V4M#	AWB High Line Voltage	Alarm	Incoming voltage is too high	<p>Check incoming voltage is correct for configuration.</p> <p>Verify the transformer has the correct tap (400, 480, 600) selected.</p>
WJ1★	Pump _ Solenoid is disconnected	Alarm	Pump is not turning on when it should	<p>Verify harness is plugged into J13 of the daughter board. Verify it is secured to the solenoid.</p> <p>Replace Solenoid.</p>
WJ2★	Pump _ Solenoid High Current	Alarm	Solenoid is drawing too much current	Inspect for short in harness. Inspect for a shorted solenoid cable/short to the ground. Replace solenoid.
WSUX	Configuration Error USB	Advisory	USB configuration is not loaded	Install software.

Ram Troubleshooting

Problem	Cause	Solution
Ram will not raise or lower.	Closed main air valve or clogged air line,	Open air valve; clear air line.
	Not enough ram air pressure.	Increase ram air pressure.
	Worn or damaged ram piston.	Replace piston. See instruction manual 310523.
	Platen not fully up to temperature.	Wait for full temperature.
	Ram air pressure too high.	Decrease ram air pressure.
	Dented drum has stopped platen.	Fix or replace drum.
Ram raises or lowers too fast.	Ram "up / down" air pressure too high.	Decrease ram air pressure.
Air leaks around cylinder rod.	Worn rod seal.	Replace o-rings in guide sleeve. See instruction manual 310523.
Fluid squeezes past platen wipers.	Ram air pressure too high.	Decrease ram air pressure.
	Worn or damaged wipers.	Replace wipers.
Pump will not prime properly, or pumps air.	Closed main air valve or clogged air line.	Open air valve; clear air line.
	Not enough air pressure.	Increase air pressure.
	Worn or damaged ram piston.	Replace piston. See instruction manual 310523.
	Ram directional valve closed or clogged.	Open valve; clear valve or exhaust.
	Ram directional valve dirty, worn, or damaged.	Clean; repair valve.
	Directional valve not in the down position.	Position handle in the down position.
	Dented drum has stopped platen.	Fix or replace drum.
Air pressure will not push platen out of drum.	Closed main air valve or clogged air line.	Open air valve; clear air line.
	Platen not fully up to temperature.	Wait for full temperature.
	Not enough blow-off air pressure.	Increase blow-off air pressure.
	Blow-off valve passage clogged.	Clean valve passage.
	Dented drum has stopped platen.	Fix or replace drum.
	Wipers bonded to drum or drum liner.	Lubricate wipers with high temperature grease at every drum change.

Heated Pump Troubleshooting

See pump manual for additional pump troubleshooting information. See [Related Manuals, page 7](#).

Problem	Cause	Solution
Rapid downstroke or upstroke (pump cavitation).	Material not heated to proper temperature.	Check and adjust temperature to proper set point. Wait for pump/platen to heat up.
	Air is trapped in pump.	Bleed air from pump. See Prime Pump, page 33 .
	Downstroke: Dirty or worn pump intake valve.	Clean or repair. See Pump Manual.
	Upstroke: Dirty or worn pump piston valve.	Clean or repair.
	Machine is out of material	Adjust empty level sensor.
Material leaks around pump outlet.	Loose outlet fitting.	Tighten outlet fitting.
Material leaks around bleed port.	Loose bleed port fitting.	Tighten bleed port fitting.
Pump will not move up and down.	Problem with air motor.	See Air Motor Manual.
	Foreign object lodged in pump.	Relieve pressure. See Pump Manual.
	Platen not fully up to temperature.	Wait for full temperature.
	Valve to air motor is off.	Check gauges and valves to the air motor.
Leak around pump wet-cup.	Worn throat seals.	Replace throat seals. See Servicing the Throat packings in manual 334127 or 334128.

Air Motor Troubleshooting

See air motor manual for additional air motor troubleshooting information. See [Related Manuals, page 7](#)

Problem	Cause	Solution
Air motor will not run.	Air motor solenoid is off.	Wait for heat zones in use to reach temperature setpoint values.
Air motor stalled.	Damaged main air valve spool or poppets.	Inspect and clean poppets. See Air Motor Manual.
		Rebuild main air valve. See Air Motor Manual.
Air continuously exhausting around air motor shaft.	Damaged air motor shaft seal.	Replace air motor shaft seal. See Air Motor Manual.
Air continuously exhausting around air valve/slide valve.	Air valve/slide valve gasket is damaged.	Replace the valve gasket. See Air Motor Manual.
Air continuously exhausting from muffler when motor is idle.	Internal seal damage.	Rebuild air motor. See Air Motor Manual.
Icing on muffler.	Air motor operating at high pressure or high cycle rate.	Reduce pressure, cycle rate, or duty cycle of motor.

Repair

Replace Wipers

1. To replace a worn or damaged wiper raise the ram plate up out of the drum. Perform steps 1 through 7 of [Change Pail, page 38](#) .
2. Separate the wiper joint, and bend back the strapping that covers the clamp (207).
3. Unscrew the worm gear and remove the wiper (202).
4. Thread the strapping through the new wiper (202).
5. Insert the strap end through the clamp (207) and tighten.
6. Use a rubber mallet to pound the wiper around the platen (201) until the wiper ends are butted tightly together.
7. Apply a lubricant to the wiper (202). Use a lubricant that is compatible with the material to be pumped. Check with the material supplier.

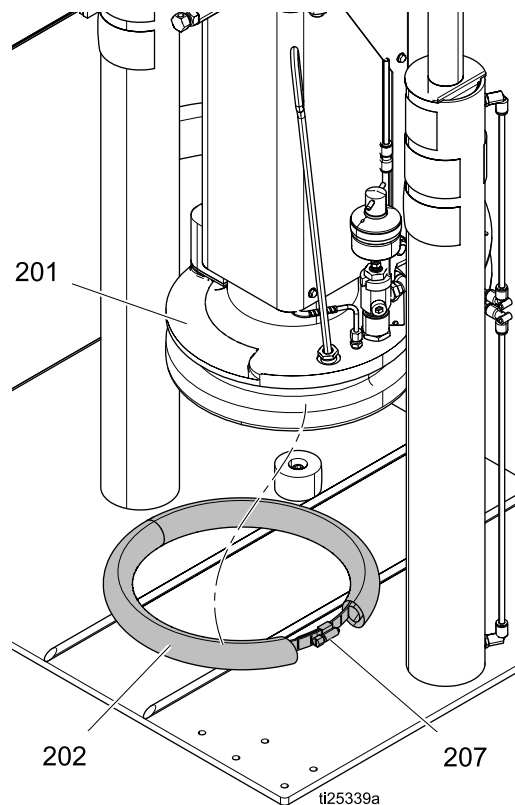
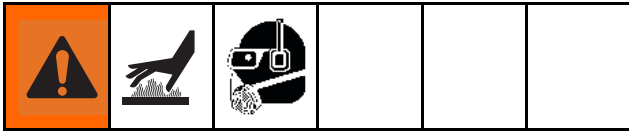

Figure 26

Replace Platen RTD



Reference [Electrical Schematics, page 60](#) for wiring connections.

1. If the material pail has already been removed from the supply unit, go to step 2. If you need to remove the material pail, see [Change Pail, page 38](#).
2. Make sure the ram plate is down and the ram hand valve is in the OFF position.

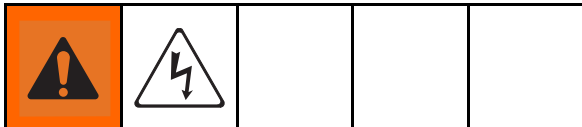
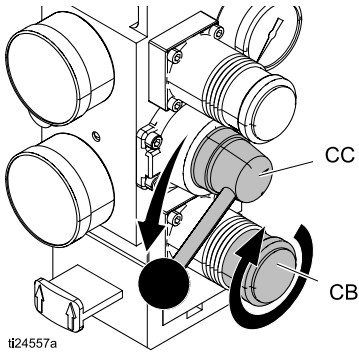

To reduce the risk of injury or damage to equipment, make sure the main power switch is off before continuing with this procedure.

3. Turn main power switch off.



4. Remove the front and right side pump cover.

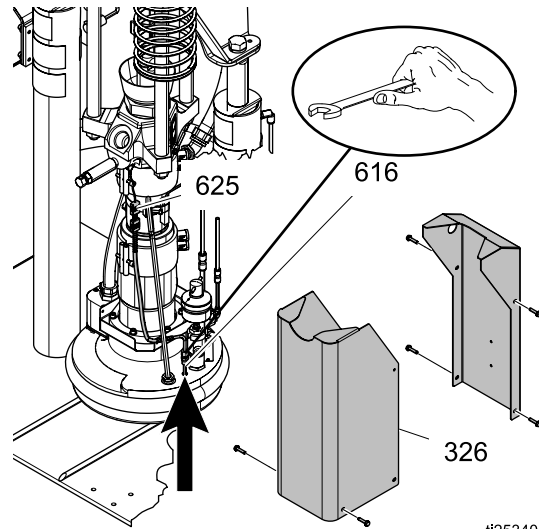

27

5. Remove the platen RTD (616) from the platen.
6. Disconnect the platen RTD quick connect terminal (625) from J5 connector on the AWB.
7. Attach the leads from the new sensor (616) to the leads of the old sensor and pull the new sensor leads through the cable pump shield, cable track, and into the electrical enclosure.
8. Install the new sensor (616) into the follower/tire plate after coating with non-silicone heat sink compound. Tighten compression nut. Ensure RTD is fully inserted.
9. Reconnect the quick connect terminal (625).
10. Replace the pump covers.

Separate the Air Motor and Pump



1. If the material drum has already been removed from the supply unit, go to step 2. If you need to remove the material pail, perform steps 1 through 6 of [Change Pail, page 38](#). Pump must be in the full down position (air motor shaft fully extended).
2. Make sure the ram plate is down and the ram director valve (CC) is in the neutral position.

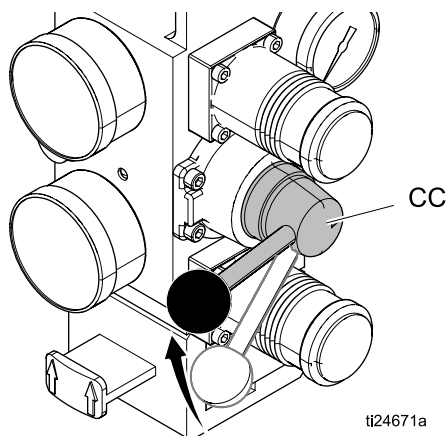

3. Follow [Pressure Relief Procedure, page 36](#).
4. Bleed off excess material and pressure in the system by opening the dispense gun and catching the material in a waste container.
5. On ADM, turn off the system heat (D).

6. Turn the main power switch off.



7. Disconnect all material hoses.
8. If system includes pump shield, remove the pump sheet metal enclosure (A). See [Fig 28](#).
 - a. Remove the cover screws (B).
 - b. Remove heater bands (HB) and disconnect the ground wire (R).
9. Pump must be in the full down position (air motor shaft fully extended).
10. If vent hood is installed, remove it.
11. Disconnect electrical cable from air motor (X).
12. Remove air line from air motor and air lines to the follower blow-off valve.
13. Remove nuts (F) from pump/air motor tie rods at the pump end.
14. Remove nuts and bolts (T) holding cable track to air motor support plate. Slide end of cable track outboard of the mounting plate.
15. Remove screws and washers from pump inlet.
16. Fully loosen pump rod coupler (G) to the air motor rod.
17. Slowly raise elevator to achieve enough separation of the pump (air motor) tie rods to remove the pump.
18. Remove the pump (P).
19. Reverse this procedure to reinstall the new or rebuilt air motor.

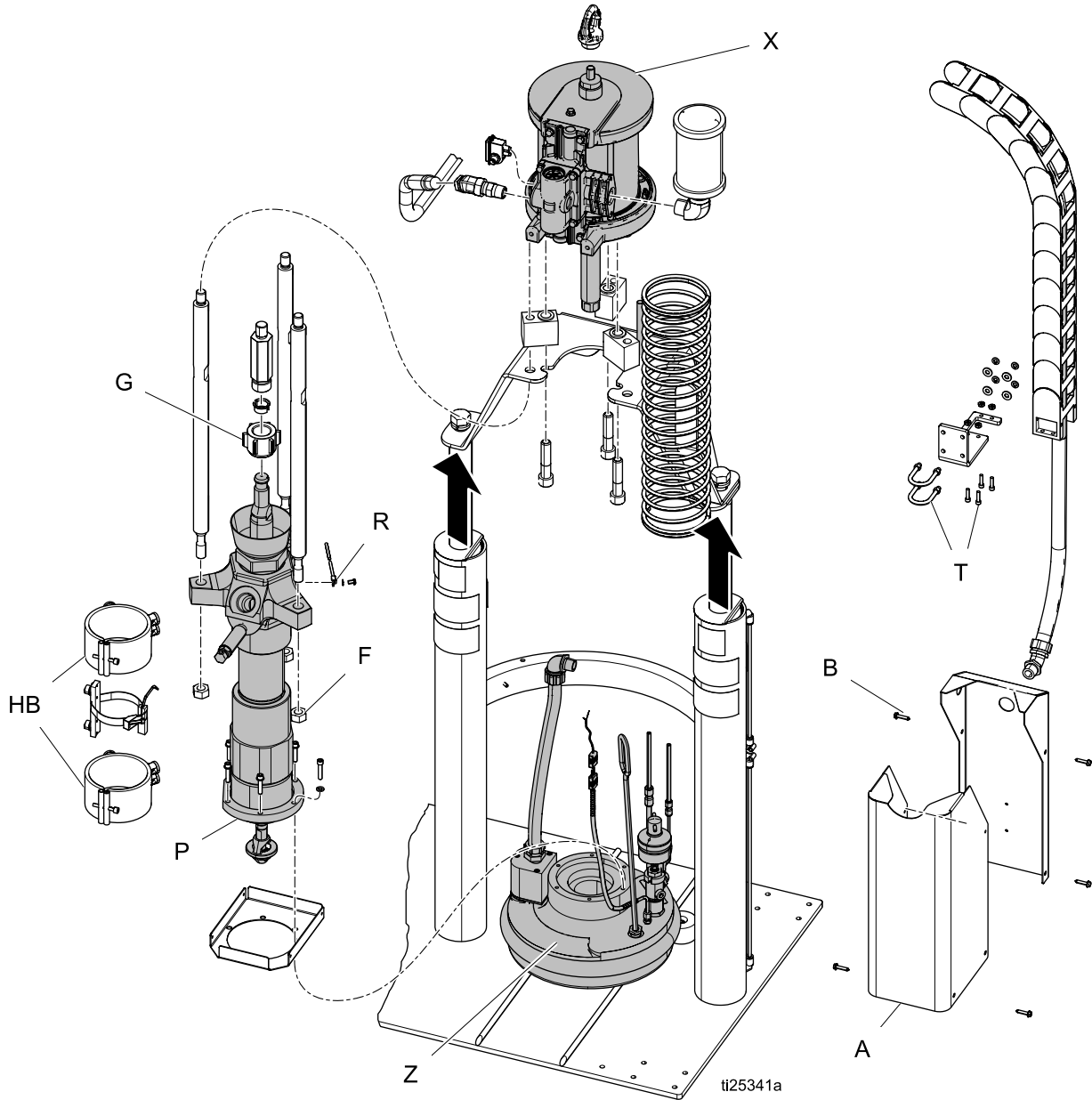
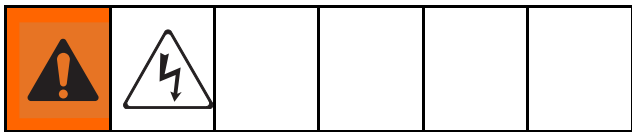

Figure 28

Remove Platen



1. Turn the main power switch off.
2. Disconnect the platen power wires and the ground wire from within the main control panel and pull out of conduit.
3. Remove the platen assembly from the ram.
4. Reverse this procedure to reinstall the new or rebuilt platen assembly.

Replace Heater Bands and Pump RTD

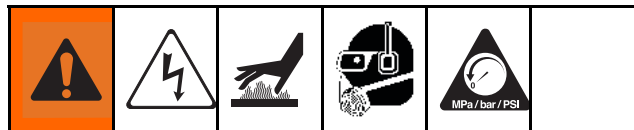

Replace Heater Band

1. If the material drum has already been removed from the supply unit, go to step 2. If you need to remove the material drum, perform steps 1 through 6 of the [Change Pail, page 38](#). Pump must be in the full down position (air motor shaft fully extended).
2. Make sure the ram plate is down and the ram hand valve is in the neutral position.
3. Follow [Pressure Relief Procedure, page 36](#).
4. Bleed off excess material in the system by opening the applicator and catching the material in a waste container.
5. On ADM, turn off the system heat (D).
6. Turn the main power switch off.

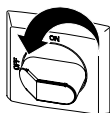

7. Remove the pump covers.
8. Remove white ceramic caps and disconnect the electrical wires from heater band (309a, 309b).
9. Remove the screw that holds the heater band in place.
10. Remove the heater band (309a, 309b) from pump.
11. Coat the inside of the heater with non silicone heat sink compound before mounting. Maximum thickness is 0.005 in. Coat only to within 3/4 in. of vertical ends.
12. Install a new heater band (309a, 309b) in the same location as the old heater band:
 - a. Locate heater terminals so they line up with back of pump.

- b. Tighten the heater band.
- c. Re-connect heater wires and re-attach ceramic caps that insulate terminal.

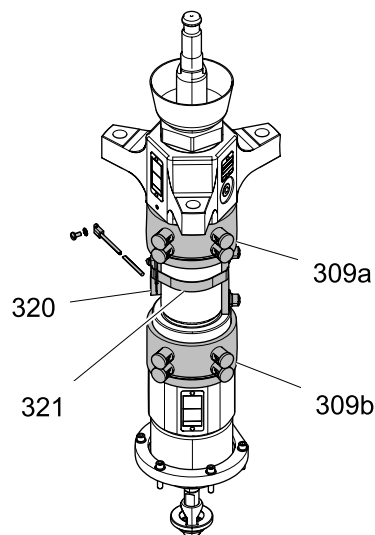

ti25342a Figure 29

Replace Pump RTD

1. Turn the main power switch off.



2. Remove the screws that hold the front shroud in place and remove front shroud.
3. If sensor wire is connected to electrical enclosure, disconnect it.
4. Loosen the clamp (321) holding sensor on pump.
5. Tie the leads of the new sensor (320) to the old sensor and remove the old sensor. The leads of the new sensor will be easily drawn through the conduit for reconnecting.
6. Replace the sensor (320) in clamp (321):
 - a. Place sensor approximately 30° counter clock-wise from pump outlet.
 - b. Tighten clamp (321).
7. Re-connect sensor wire to electrical enclosure.

Replace MZLP Fuse

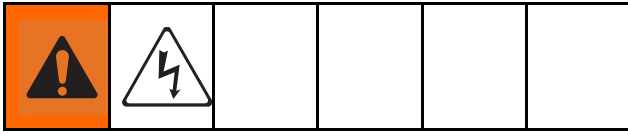

Each MZLP module comes with the following fuses:

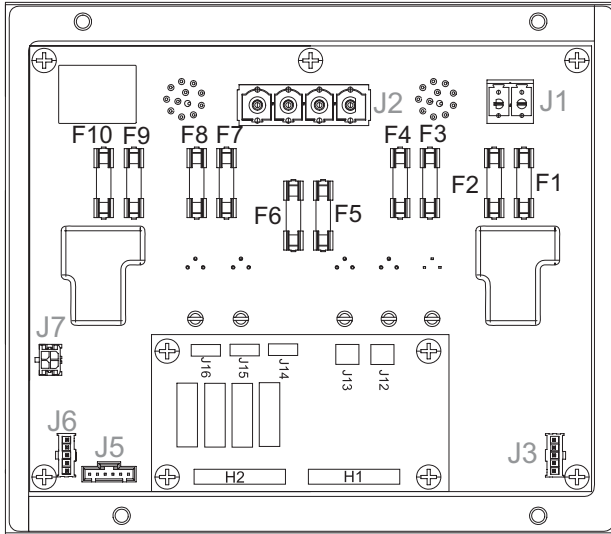

Figure 30 Fuse Locations

Fuse Kit	Fuse	Part
24V289	F1, F2	250VAC, 25A, long, white ceramic
	F3-F10	250VAC, 8A, fast acting, clear glass
Spare fuse kit included with system.		

NOTICE

To prevent system damage, always use fast acting fuses. Fast acting fuses are required for short-circuit protection.

1. Turn the main power switch off.



2. Open electrical enclosure door.

3. Use a proper non-conductive fuse puller tool to remove the blown fuse.

NOTICE

Using an improper tool, such as screw drivers or pliers, may break glass on fuse.

Note

F1 and F2 are white ceramic and indicate 25A on the barrel.

Note

F3-F10 are clear glass and indicate 8A on the barrel.

4. Use a proper non-conductive fuse puller tool to install the new fuse

NOTICE

Using an improper tool, such as screw drivers or pliers, may break glass on fuse.

5. Close electrical enclosure.

Replace MZLP



1. Turn the main power switch off.

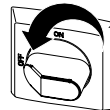

2. Disconnect heated hose electrical connectors from MZLP (111 or 112).
3. Note location of each cable, then unplug all cables from the MZLP (111 or 112) that will be replaced.
4. Remove four screws (115) securing MZLP (111 or 112) to electrical enclosure then carefully remove MZLP from electrical enclosure.

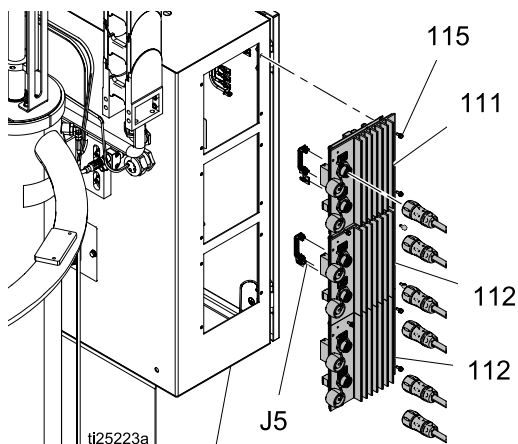

Figure 31 MZLP Identification

5. Replace MZLP.
 - a. To replace MZLP #1, remove the daughter card and standoffs, and re-install them on the new MZLP #1.
 - b. To replace MZLP #2 or #33, remove the jumper (162) from MZLP #2 or #3 J5 connector and reinstall it on the new MZLP J5 connector.
6. To reassemble MZLP, Set MZLP rotary switch based on location. See **MZLP Rotary Switch Table**.
7. Use four screws (115) to install MZLP (111 or 112) to electrical enclosure.

8. Reconnect cables to MZLP.

Note

Do not force the electrical connection. Minimal force is required to seat the connector. If resistance is felt, stop and verify the connector orientation.

Note

If unable to determine connector location, see [Electrical Schematics, page 60](#).

9. Connect heated hose electrical connectors to new MZLP.

Note

MZLP may need updated software. See [Update Software, page 59](#).

Table 10 MZLP Rotary Switch

MZLP	System	Rotary Switch
#1 with Daughter Card	Primary	1
	Secondary	5
#2	Primary	2
	Secondary	6
#3	Primary	3
	Secondary	7

Replace MZLP Daughter Card

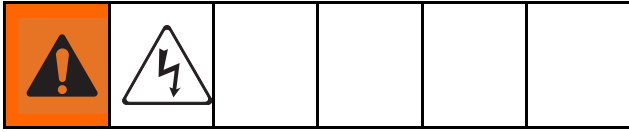

1. Turn the main power switch off.



2. Note location of each cable then unplug all cables from MZLP daughter card on MZLP#1 (112).
3. Remove four mounting screws (112b) from daughter card (112a) and set aside.
4. Unplug daughter card (112a) from the MZLP #1 (112).

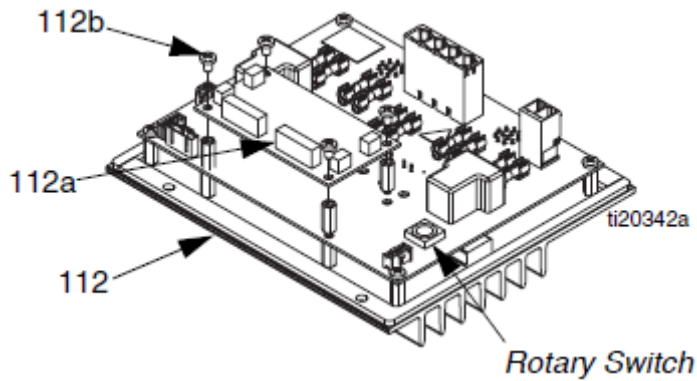

Figure 32 MZLP Daughter Card

5. Plug new daughter card (112a) into the MZLP (112).
6. Use screws (112b) to secure daughter card to MZLP (112).
7. Connect cables to new daughter card (112a).

Note

Do not force the electrical connection. Minimal force is required to seat the connector. If resistance is felt, stop and verify the connector orientation.

Note

If unable to determine connector location, see [Electrical Schematics, page 60](#).

Replace AWB

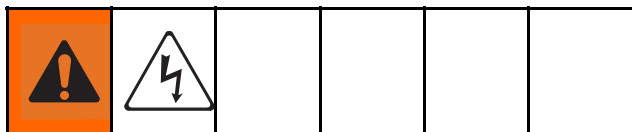

1. Turn the main power switch off.

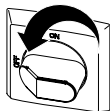

2. Note location of each cable, then unplug all cables from the AWB (205).

Note

For an AWB on a secondary system, remove connector (182) and connect to new AWB.

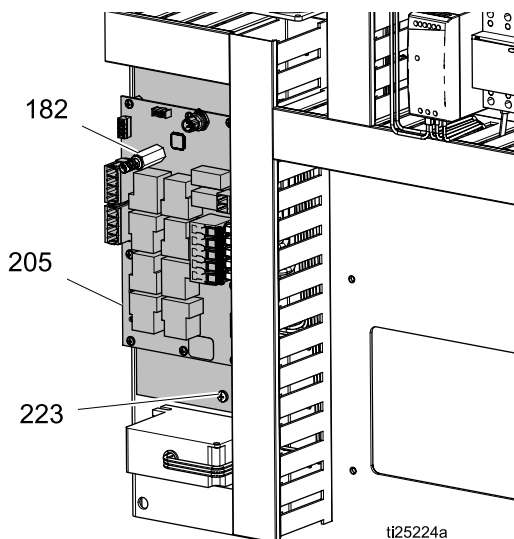

Figure 33 AWB Connections

3. Remove two screws (223) securing AWB (205) to electrical panel then carefully remove AWB.
4. Install new AWB (205) and reconnect cables.

Note

Do not force the electrical connection. Minimal force is required to set the connector. If resistance is felt, stop and verify the connector orientation.

Note

See [Electrical Schematics, page 60](#), if unable to determine the connector location.

Replace Power Supply

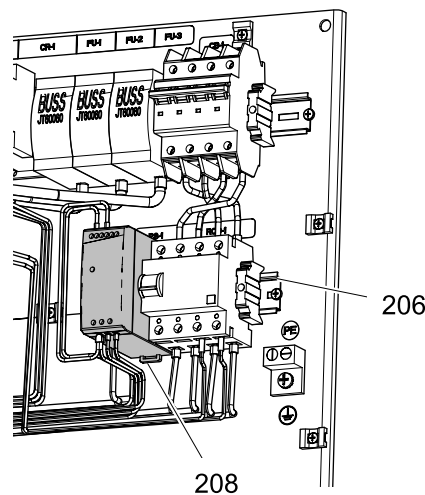

1. Turn the main power switch off.



2. Open electrical enclosure.
3. Remove power supply (208) from din rail (206). Disconnect screw terminal connections between the power supply and power supply harness.

Power Supply Connection	Harness Label
V+	V+
V-	V-
GND	GND
L	L
N	N

4. Connect power supply harness to new power supply.
5. Reattach power supply to din rail (206).
6. Torque terminals to 4.53–6.2 in-lbs (0.5–0.7 N•m).
7. Close electrical enclosure door.

Replace Fan

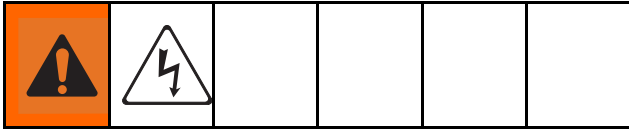

1. Turn the main power switch off.

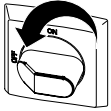

2. Disconnect plug from power outlet or turn off circuit breaker for incoming power.
3. Open electrical enclosure door.
4. Remove connector from J7 connector on AWB board. Remove red (+) and black (-) fan wires from connector.

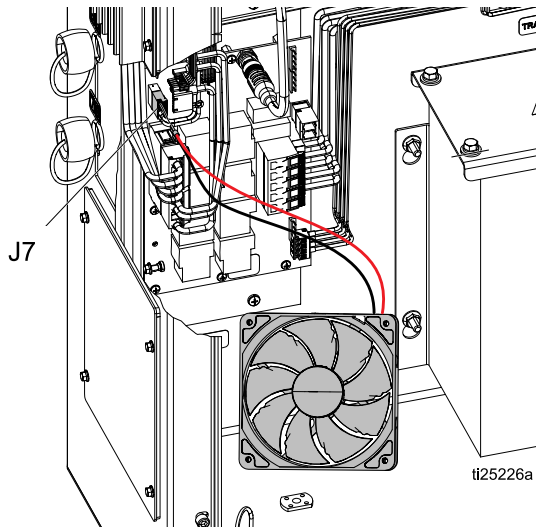

5. Cut any cable ties between the end of the fan wires to the fan (136).

6. Remove screws (141), grill (137), four nuts (139), rear fan grill (138), and fan (136).

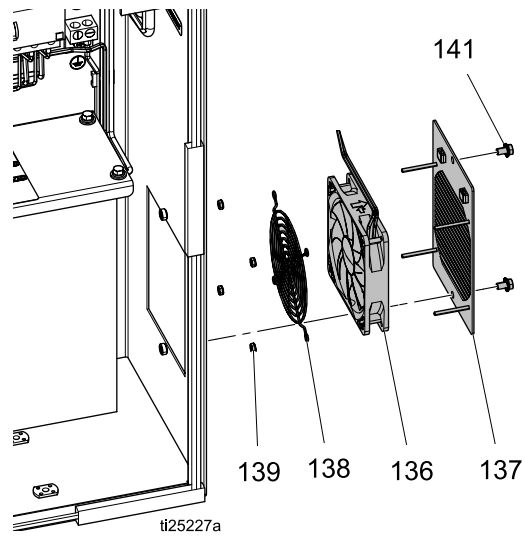

7. Mount new fan (136), rear fan grill (138), and nuts (139) on grill (137) with the arrow pointing toward the grill (137).
8. Tie down fan wires onto tie down locations on grill (137) using cable zip ties.
9. Route fan wires into the electrical enclosure. Connect red and black fan wires to J7 connector. Reconnect J7 connector to AWB. Use cable ties to secure fan wires to other cables in electrical enclosure.

Note

To prevent fan errors on ADM, remove excess slack and ensure cabling and zip ties do not contact fan blades.

10. Reinstall fan grill (137) and close the electrical enclosure.

Replace Transformer

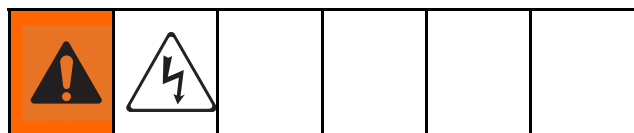

See Fig 35, page 57.

1. Turn the main power switch off.

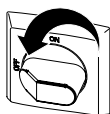

2. Open electrical enclosure door.
3. Disconnect incoming power harness (234) from top of transformer (235).
4. Disconnect transformer (235) output power harness wires (RCD-W1, -W2, -W3, -W4) from RCD-1.
5. Disconnect transformer (235) ground wire from the back panel ground lug.
6. Disconnect the red (+) and black (-) wire of fan from pins 4 and 3 of J7 connector on AWB (205). Disconnect J7 connector from AWB.
7. Cut wire zip ties securing fan wires.
8. Remove flanged nuts (N) and transformer (235) from the back panel (201).
9. Install transformer (235) onto mounting studs on back panel (201) and secure with flanged nuts (N).
10. Insert thermal sensor connector from transformer (235) onto J7 connector on AWB (205).
11. Reconnect red (+) wire from fan into pin 4 and the black (-) wire into pin 3 of J7 connector.
12. Install transformer (235) ground wire onto ground lug of back panel (201).

13. Connect transformer output power harness (234) to power terminal connections. Torque to 25–27 in-lbs (2.8–3.1 N•m).

Table 11 Transformer Output Power Harness Connections

Power Harness Wires	RCD-1 Connections
RCD-W1	Terminal N
RCD-W2	Terminal 5
RCD-W3	Terminal 3
RCD-W4	Terminal 1

14. Install incoming power harness (234) to top of transformer in voltage port specified on machine serial number label.

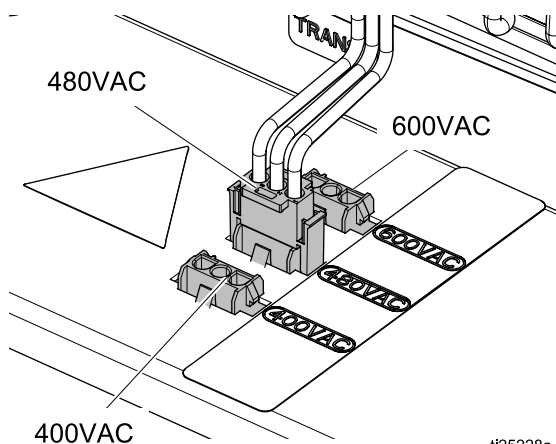

ti25228a

15. Verify all electrical connections, including earth grounds, are complete and tight. All connections and plugs must be connected prior to applying power.
16. Close the electrical control panel door.
17. Apply power to the machine. Turn on the main power switch.
18. Restart the system.

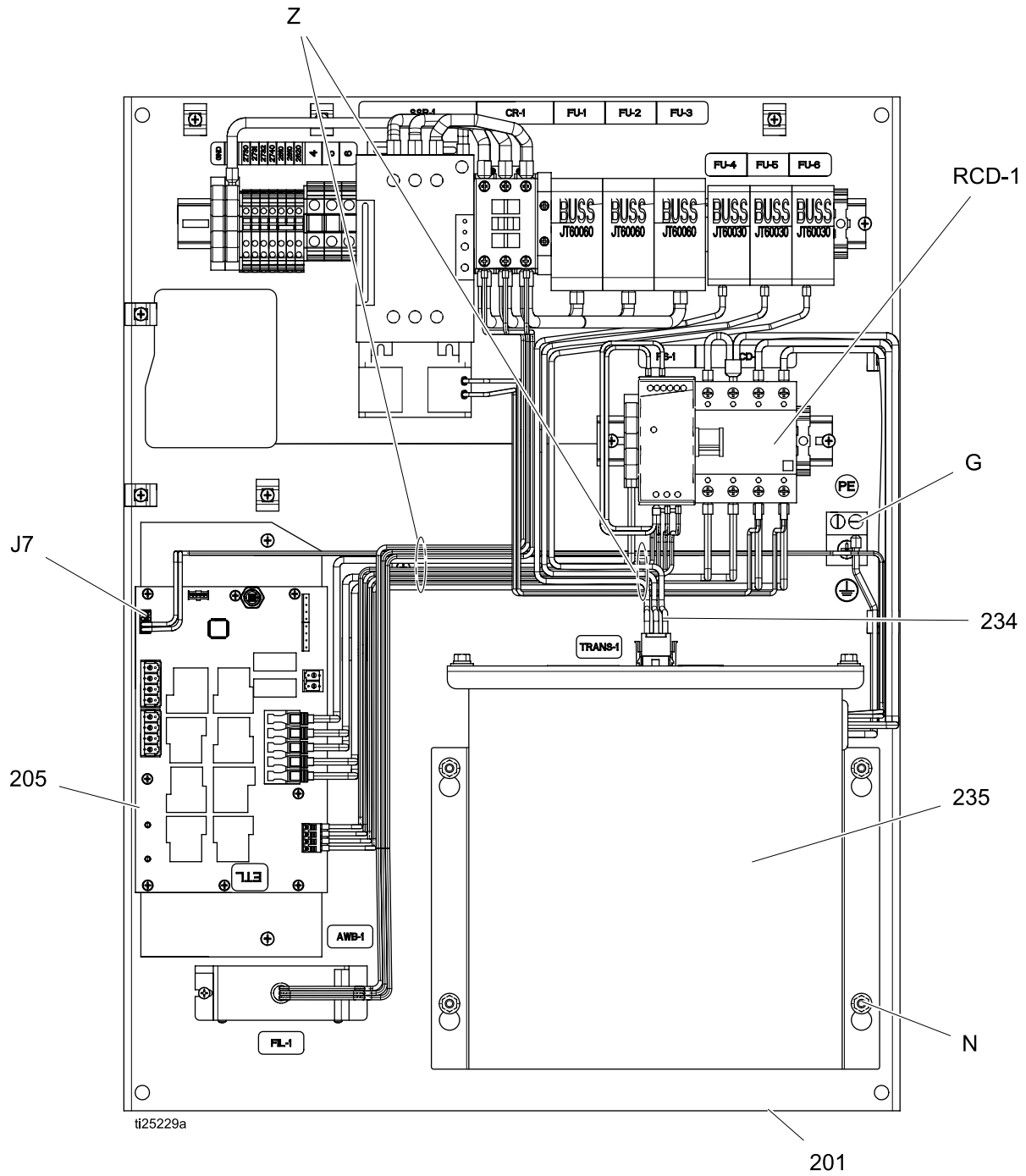
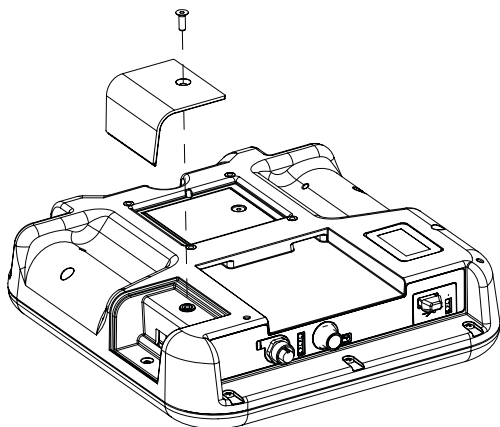

Figure 34 Inside of Electrical Control Enclosure

Update Software

When software is updated on the ADM the software is then automatically updated on all connected GCA components. A status screen is shown while software is updating to indicate progress.

1. Turn system main power switch OFF.
2. Remove ADM from bracket.
3. Remove token access panel.



4. Insert and press software upgrade token (T) firmly into slot.

Note

There is no preferred orientation of token

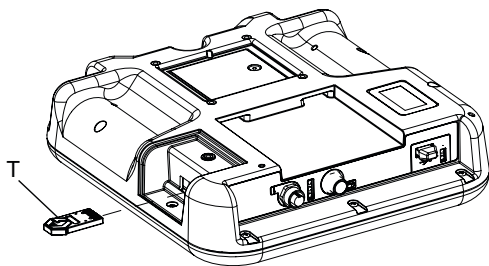

5. Install ADM into bracket.
6. Turn system main power switch ON.

NOTICE

A status is shown while software is updating to indicate progress. To prevent corrupting the software load, do not remove token until the status screen disappears.

Note

When the screen turns on, you will see the following screens:

<p>First: Software is checking which GCA modules will take the available updates.</p>	<p>The GRACO logo is displayed at the top. Below it, a status screen shows a progress bar with a small icon of a device and a document, indicating the software is checking for updates.</p>
<p>Second: Status of the update with approximate time until completion.</p>	<p>The status screen shows a progress bar that is partially filled. Above the bar is a small icon of a device and a document. Below the bar, the time remaining is shown as 00:08 to 00:40.</p>
<p>Third: Updates are complete. Icon indicates update success/failure. See the following Icon table.</p>	<p>The status screen shows a progress bar that is almost full. Above the bar is a small icon of a device and a document. Below the bar, the time remaining is shown as 00:54 to 00:00. A refresh icon is visible in the bottom right corner.</p>

Icon	Description
	Update successful.
	Update unsuccessful.
	Update complete, no changes necessary.
	Update was successful/complete but one or more HCA modules did not have a CAN boot-loader so software was not updated on that module.

7. Remove token (T).
8. Replace token access panel.
9. Press  to continue to the operation screens.

Electrical Schematics

230V, 3 Phase/60 Hz

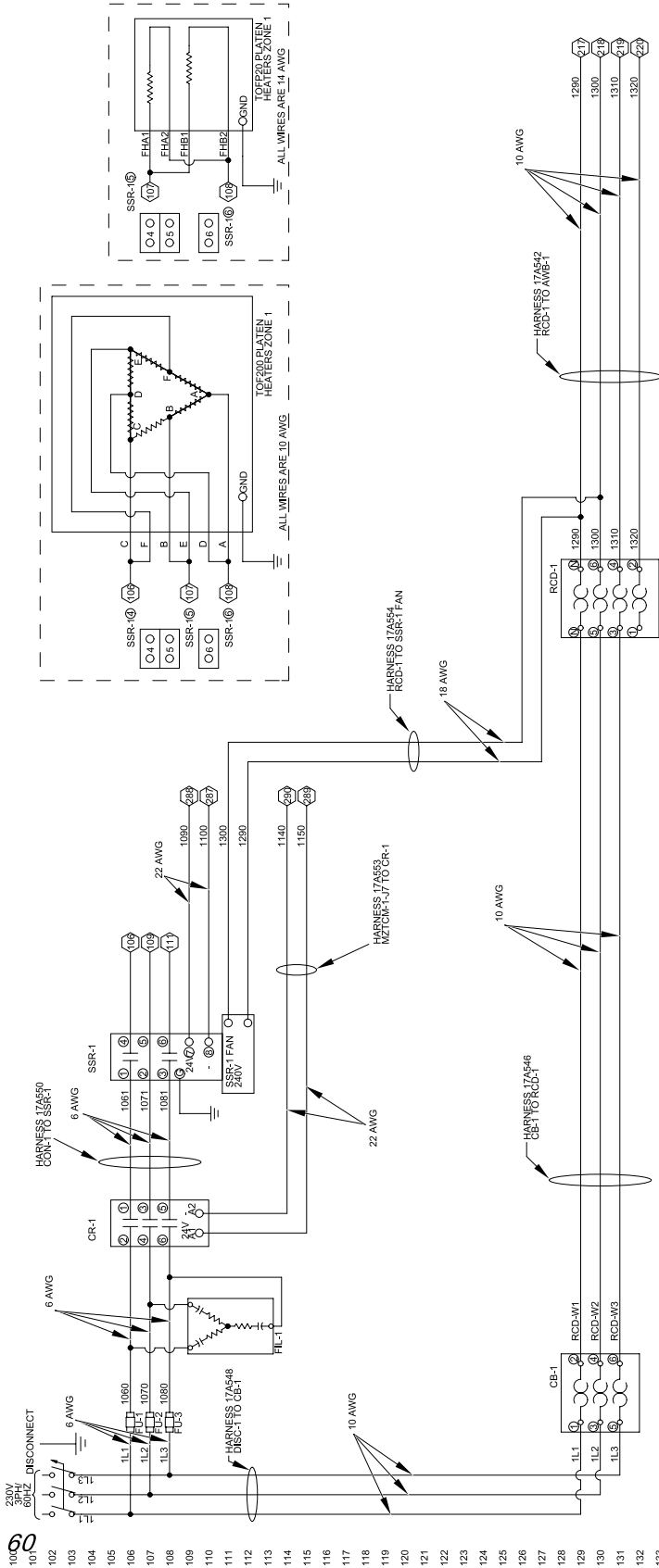

ti25120b_17C029H-2 of 7

400V, 3 Phase/50 Hz

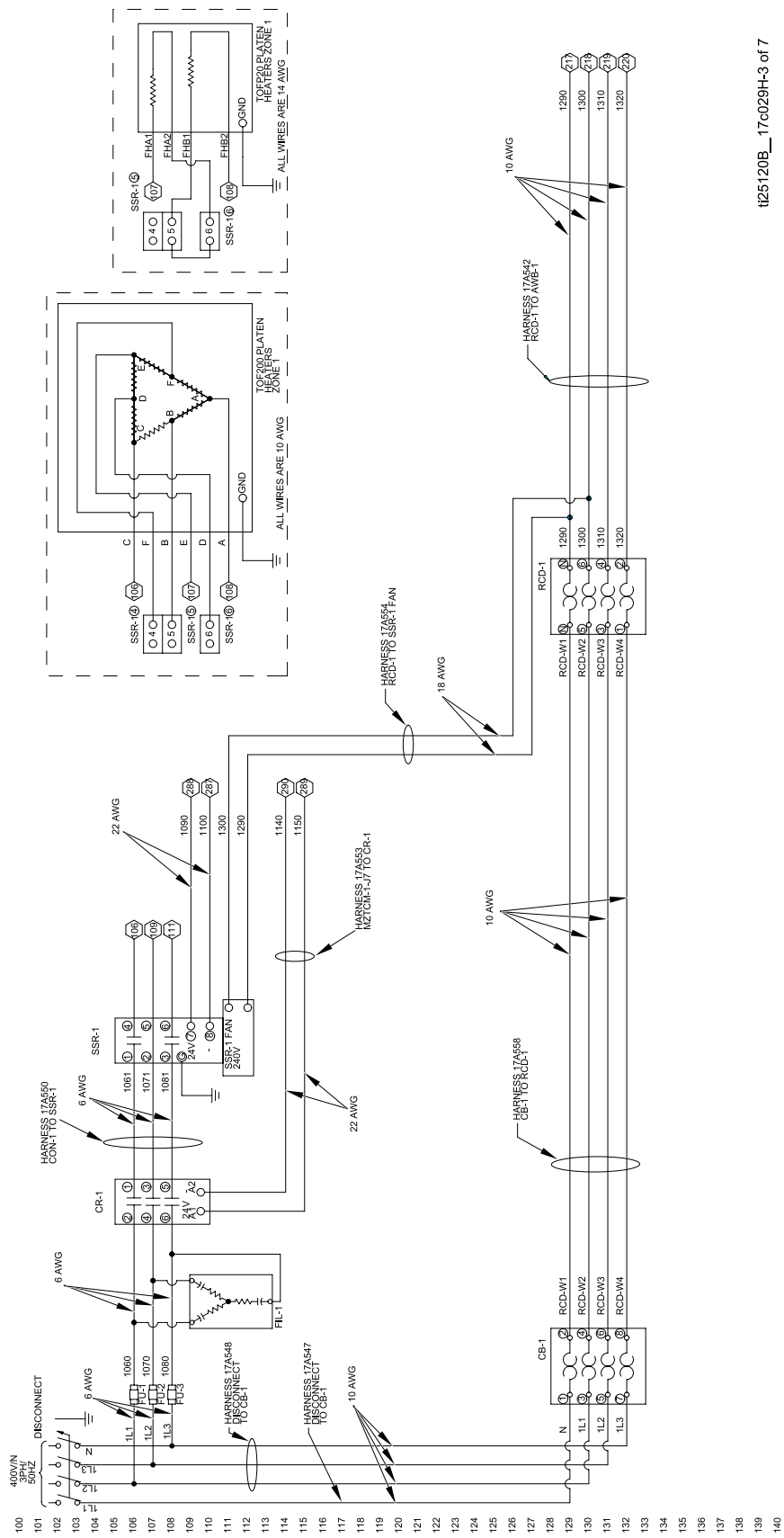

1125120B_17c029H-3 of 7

400-600VV, 3 Phase/60 Hz

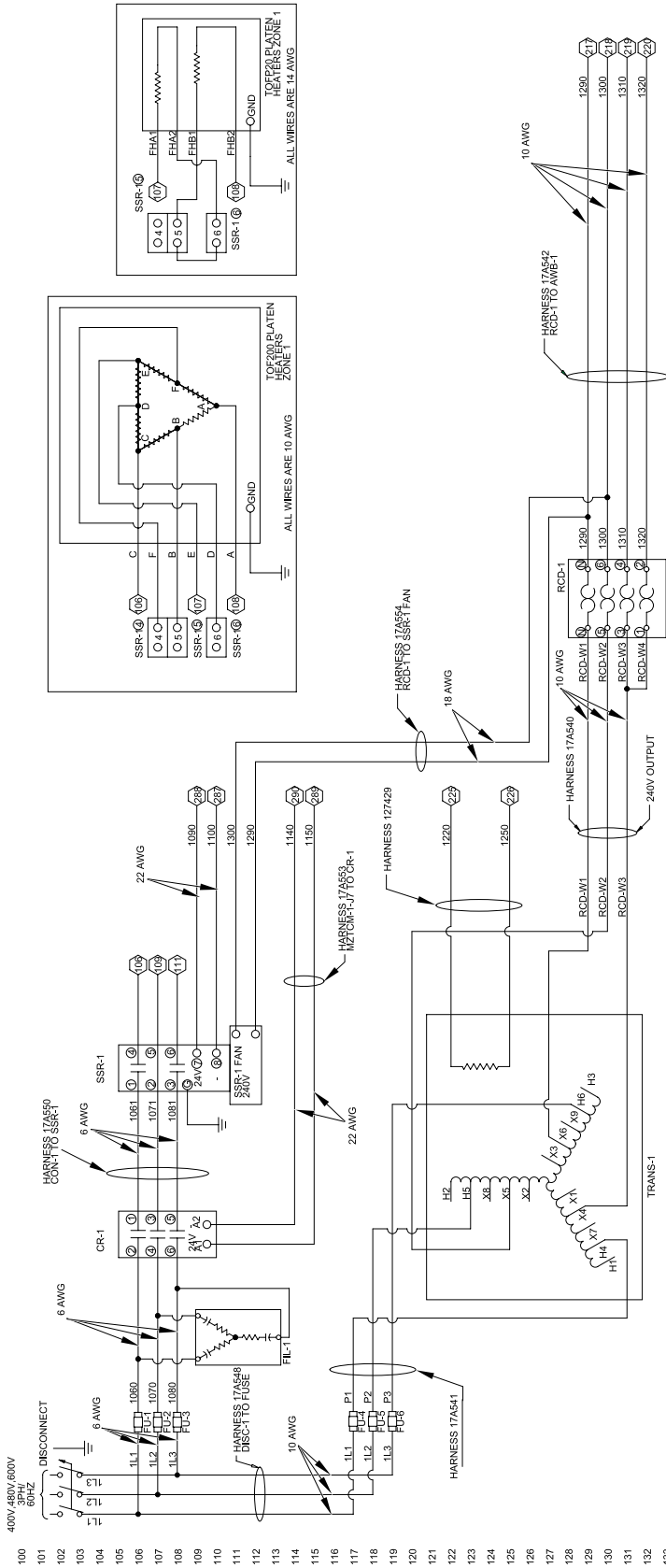

t125120B_17c029H-4 of 7

AWB and MZLP#1

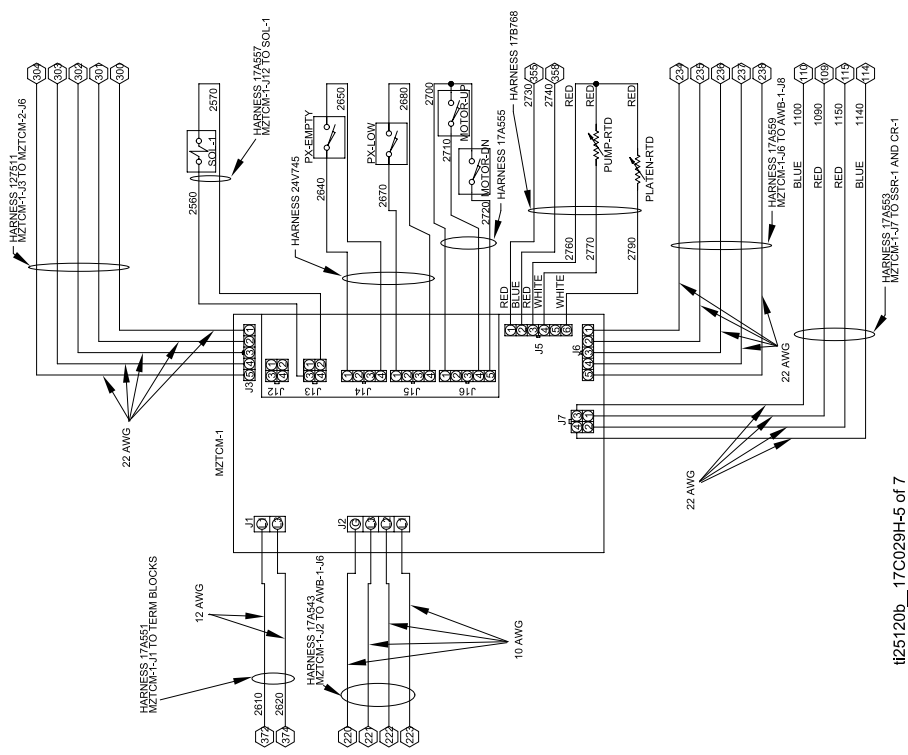

1125120b_17C029H-5 of 7

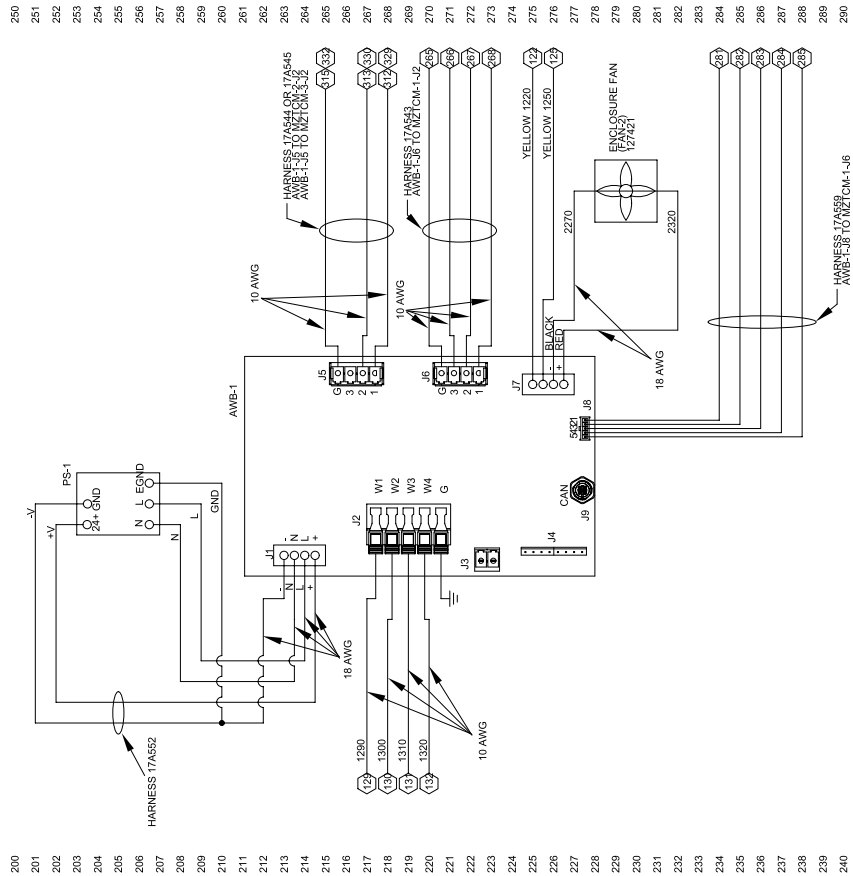

MZLP #2, MZLP#3, Overtemp, and Pump Heaters

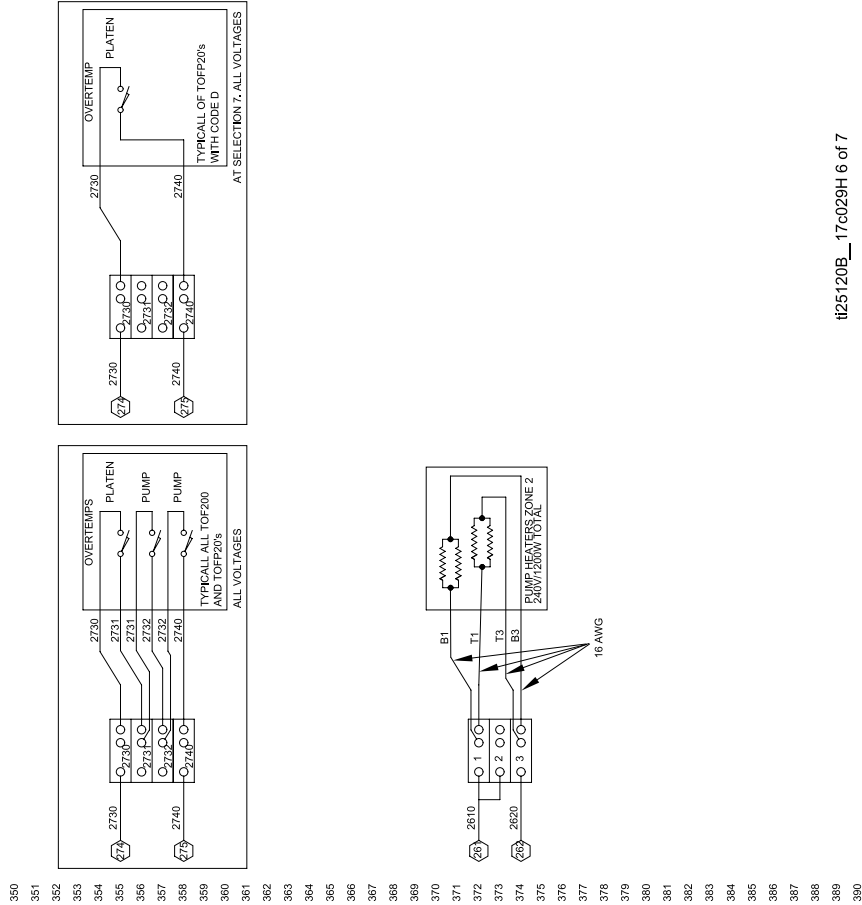
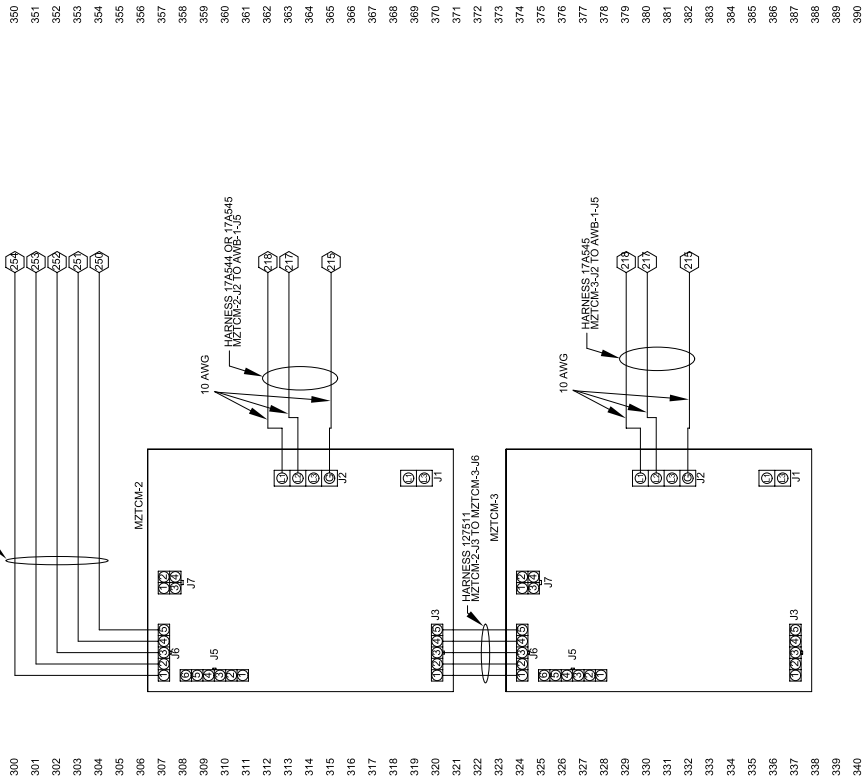

1f25120B_17c029H 6 of 7

MZLP Zones

400
401
402
403
404
405
406
407
408
409
410
411
412
413
414
415
416
417
418
419
420
421
422
423
424
425
426
427
428
429
430
431
432
433
434
435
436
437
438
439
440

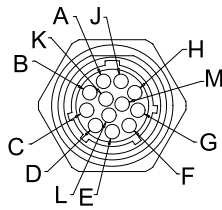
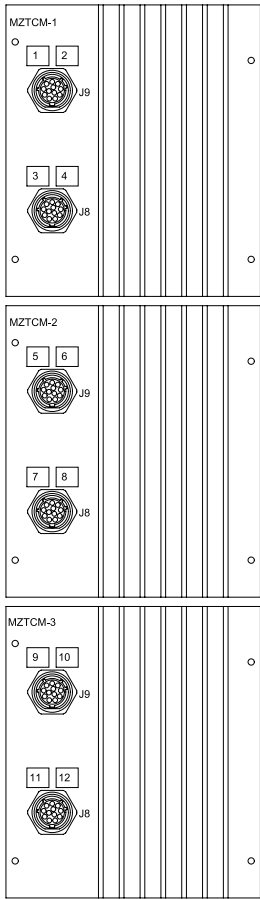

TYPICAL ZONE PIN OUT

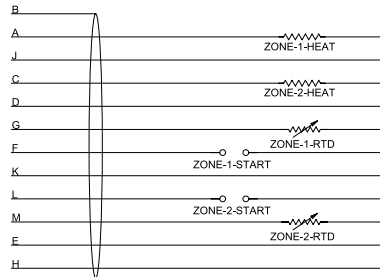

ti25120B_17C029H 7 of 7

Parts

Therm-O-Flow 20 Supply Unit

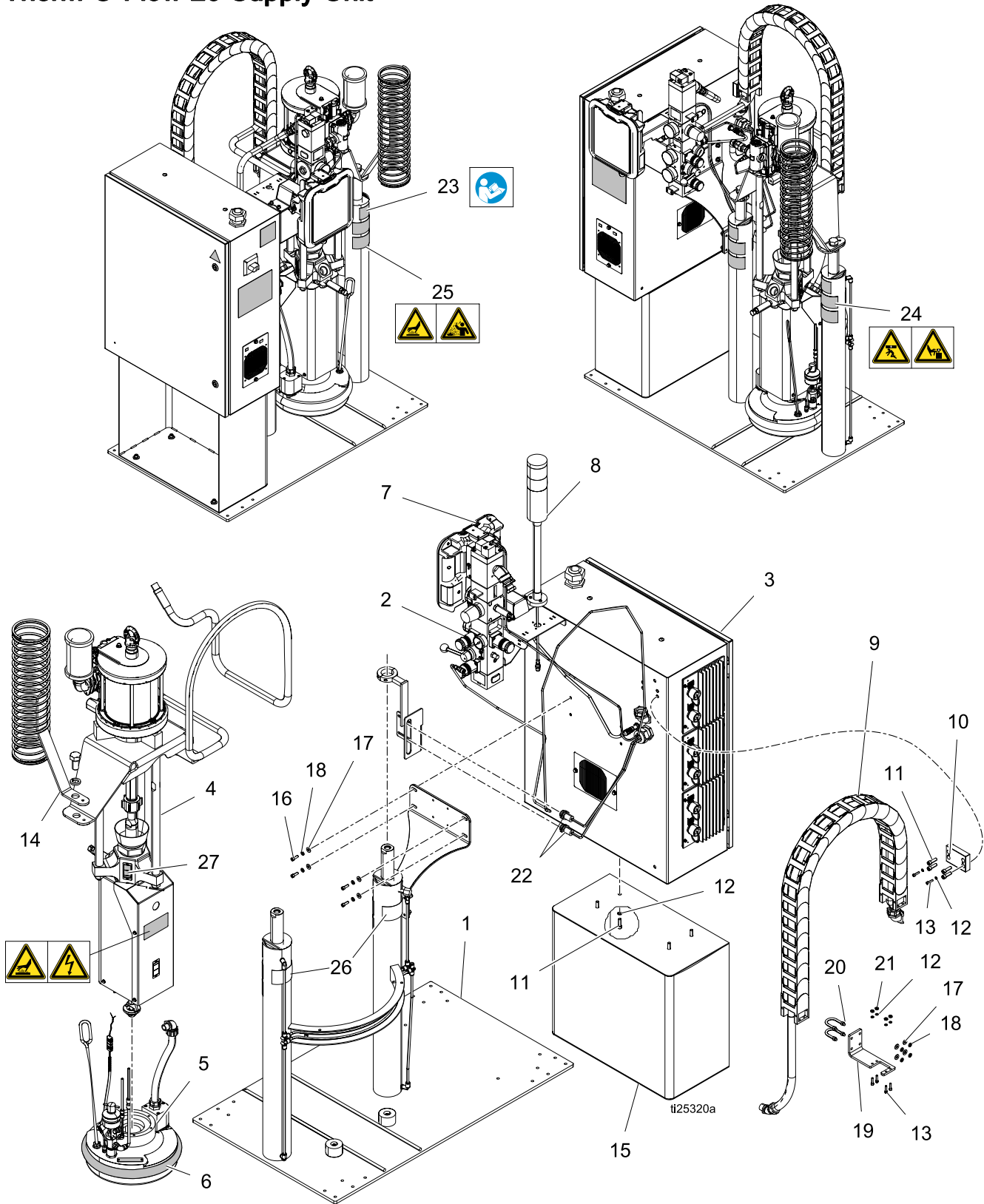

Therm-O-Flow 20 Supply Unit

Ref	Part	Description	Qty	Ref	Part	Description	Qty
1	- - -	Frame	1	14	288543	BRACKET, hose, spring	1
2	24W870	KIT; air control; see Air Control Assembly	1	15	- - -	BRACKET, enclosure, ram	1
3	- - -	CONTROL, electrical (not used with air control only systems)	1	16	112166	SCREW, cap, sch	4
4	- - -	MODULE, pump; see Pump Modules	1	17	110755	WASHER, plain	8
5	- - -	PLATEN; see Heated Platens	1	18	100016	WASHER, lock	8
6	C31065	SEAL	1	19	- - -	BRACKET, cable track, NXT	1
7	24W812	ADM	1	20	106285	BOLT, u	2
8	24W589	KIT, light tower (optional); see Accessories and Kits , page 87	1	21	100179	NUT, hex mscr	4
9	- - -	CABLE, track	1	22	24V745	SENSOR, level, low/empty	1
10	- - -	BRACKET, cable track, enclosure	1	23▲	15J076	LABEL, warning, instructions	2
11	101864	SCREW, cap, sch	4	24▲	15J074	LABEL, warning; moving objects, pinch	4
12	100020	WASHER, lock	6	25▲	15H668	LABEL, warning; hot surface, splatter	2
13	111820	SCREW, cap, sch	6	26▲	15J075	LABEL, warning; hot surface, shock	2
				27▲	184090	LABEL, warning	1

Air Control Assembly

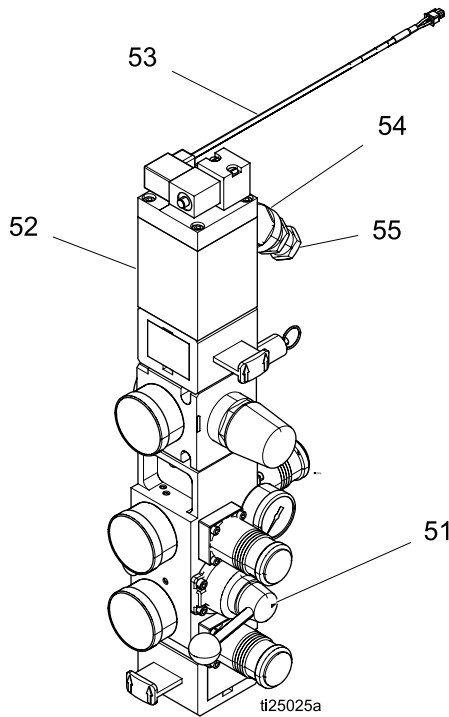

Integrated Control For
TOF With Electrical Enclosure

Ref	Part	Description	Qty
51	24W870	KIT, CONTROL, air, 3 regulator; see manual 334201	1
52	121235	SOLENOID, air motor, ram	1
53	17A557	HARNESS, solenoid, MZLP	1

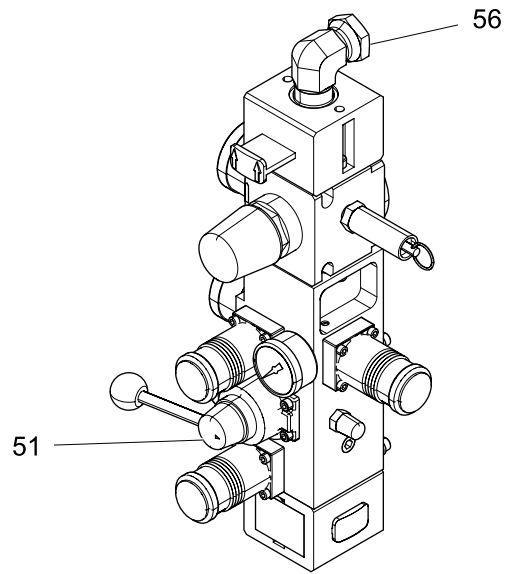

Integrated Control For
TOF Without Electrical Enclosure

Ref	Part	Description	Qty
51	24W870	KIT, CONTROL, air, 3 regulator; see manual 334201	1
54	113445	FITTING, elbow, street	1
55	121282	FITTING, swivel, straight	1
56	120375	ADAPTER, elbow, 3/4-14 nptf x 1/2-14 npsm	1

▲ Replacement Warning labels, signs, tags, and cards are available at no cost.

Electrical Module

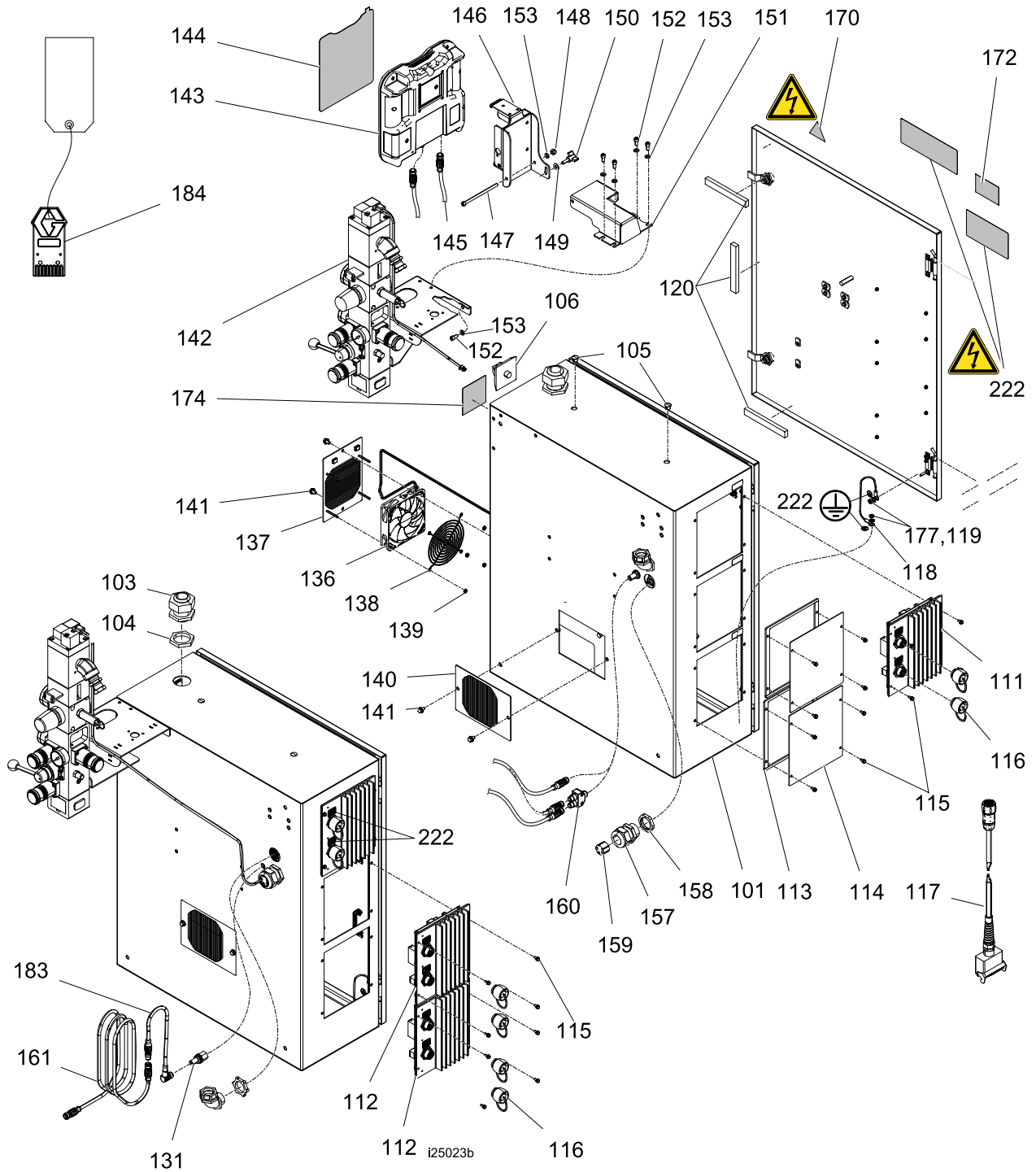

Parts

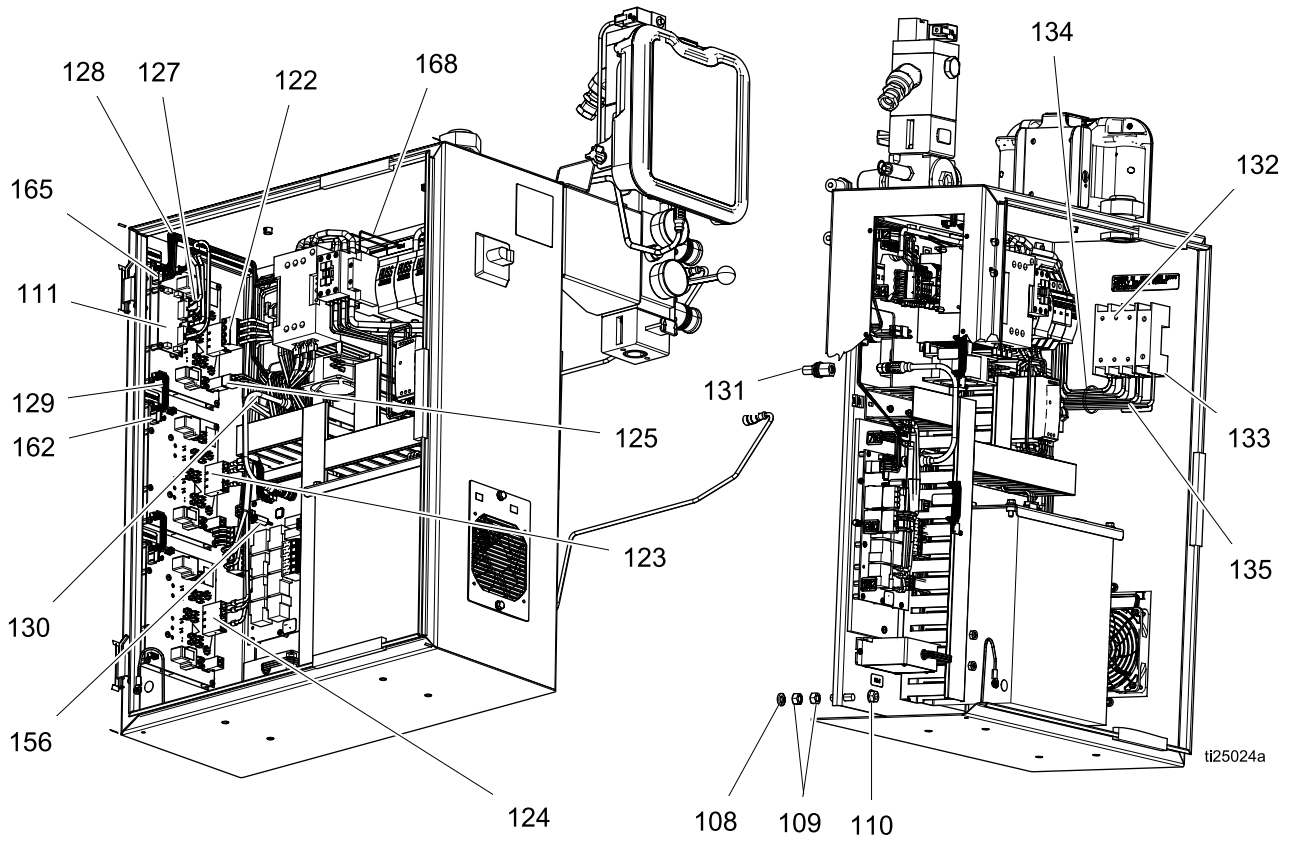
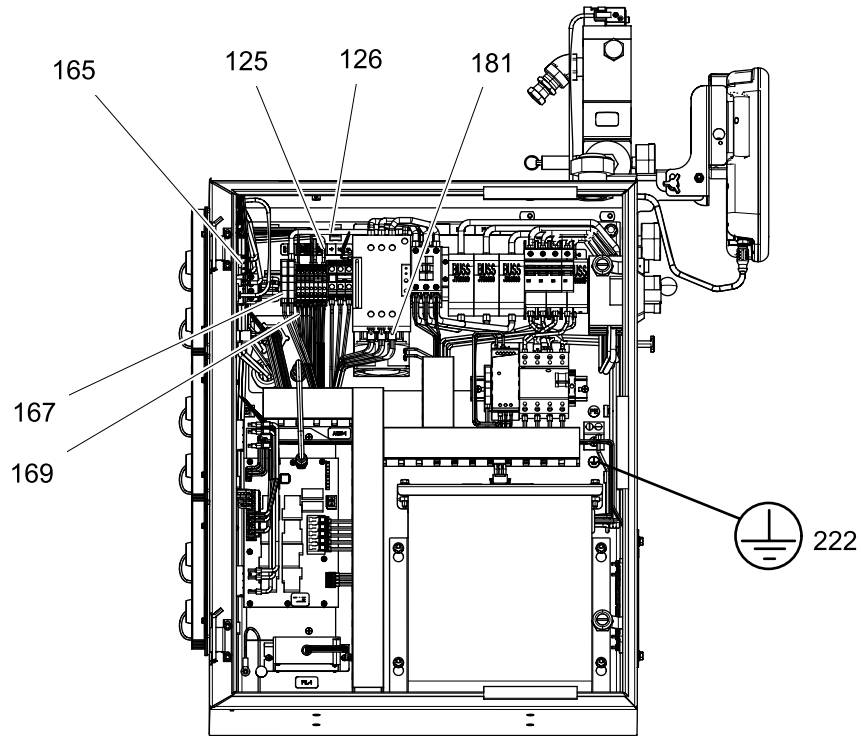

Electrical Control Module Parts

Ref.	Part	Description	Qty	Ref.	Part	Description	Qty
101	- - -	ENCLOSURE, electrical	1	123	17A544	HARNESS, power, mzl2p2, awb <i>(8 zone assemblies only)</i>	1
103	- - -	BUSHING, strain relief, m40 thread	1				
104	- - -	NUT, strain relief, m40 thread	1		17A545	HARNESS, power, mzl2p2/3, awb <i>(12 zone assemblies only)</i>	1
105	125946	PLUG, hole, 1/2 in	2	125	- - -	HARNESS, pump, mzl2p1, tb, tof	1
106	123967	KNOB, operator disconnect	1	126	- - -	HARNESS, output, mzl2p1, ssr, contact	1
107	- - -	PANEL, elec, transformer <i>(transformer assemblies only)</i>	1	127	17A555	HARNESS, pump, reed switch, tof	1
	- - -	PANEL, elec, 400v/n <i>(400V modules only)</i>	1	128	17A559	HARNESS, board, mxm, comm	1
	- - -	PANEL, elec, 230v <i>(230V modules only)</i>	1	129	127511	CABLE, board, samtec <i>(8 zone assemblies only; Qty 1) (12 zone assemblies only; Qty 2)</i>	
108	100133	WASHER, lock, 3/8	4	130	121226	CABLE, can, male / female, 0.4m	1
109	100307	NUT, hex	8	131	121612	CONNECTOR, thru, m12, mxf	1
110	123396	NUT, flange, serrated, 3/8-16	4	132	123969	SWITCH, disconnect, 100a	1
111	24V509	MODULE, gca, mzl2p w/ daughter board	1		123968	SWITCH, disconnect, ph exp 100 A <i>(400V only)</i>	1
112	24V510	MODULE, gca, mzl2p <i>(8 zone assemblies only; Qty 1) (12 zone assemblies only; Qty 2)</i>		134	- - -	HARNESS, disc, fuse, 230-600v	1
112a	24R042	KIT, daughter, board	1		17A547	HARNESS, disc, cb, 400v/n, tof <i>(400V only)</i>	1
113	- - -	GASKET, foam <i>(8 zone assemblies only; Qty 1) (12 zone assemblies only; Qty 2)</i>		136	24V911	FAN, 24v dc, 120m x 120m <i>(400V only)</i>	1
114	24P175	PLATE, blank <i>(4 Zone assemblies only; Qty 2) (8 zone assemblies only; Qty 1)</i>		137	16X884	GRILL, fan <i>(400V only)</i>	1
115	125856	SCREW, 8-32, serrated flange	12	138	115836	GUARD, finger <i>(400V only)</i>	1
116	16T440	CAP, souriau, uts14 <i>(4 Zone only; Qty 2) (8 zone assemblies only; Qty 4) (12 zone assemblies only; Qty 6)</i>		139	127278	NUT, keps, hex <i>(400V only)</i>	4
117	17C694	CABLE, tof, lapp to souriau <i>(4 Zone only; Qty 2) (8 zone assemblies only; Qty 4) (12 zone assemblies only; Qty 6)</i>		140	24V746	GRILL, vent <i>(230V and 400V assemblies only; Qty 2) (Transformer assemblies only; Qty 1)</i>	
118	- - -	WIRE, grounding, door	1	141	119865	SCREW, mach, hex serrated	4
119	100166	NUT, full hex	2	142	- - -	CONTROL, air, assy; with solenoid	1
120	- - -	GASKET, hphm	1	143	24W812	ADM <i>(Primary assemblies only)</i>	1
122	17A543	HARNESS, power, mzl2p1, awb	1	144	15V551	SHIELD, membrane, ADM <i>(Primary assemblies only)</i>	0.1
				145	121001	CABLE, can, female / female 1.0m <i>(Primary assemblies only)</i>	1

Parts

Ref.	Part	Description	Qty	Ref.	Part	Description	Qty
146	- - -	BRACKET, mounting, assembly <i>(Primary assemblies only)</i>	1	164	- - -	TUBE, 1/16 shrink tube	0.13
147	121250	SCREW, shcs, 1/4uncx4.25 <i>(Primary assemblies only)</i>	1	165	- - -	HARNESS, input, mzl1, RTD	1
148	102040	NUT, lock, hex <i>(Primary assemblies only)</i>	1	166	127771	BRIDGE, plug-in, 2pos, ut16 <i>(400V and Transformer modules only)</i>	1
149	110755	WASHER, plain <i>(Primary assemblies only)</i>	1	167	- - -	FERRULE, wire, 10awg <i>(230V modules only; Qty 2) (400V and transformer modules only; Qty 8)</i>	
150	121253	KNOB, display adj., ram pkgs <i>(Primary assemblies only)</i>	1	168	- - -	FERRULE, wire, 16awg	6
151	- - -	BRACKET, pendant pivot, <i>(Primary assemblies only)</i>	1	169	- - -	FERRULE, wire, 18 awg, long	6
152	101550	SCREW, cap, sch <i>(Primary assemblies only)</i>	4	170	196548	LABEL, warning, shock	1
153	100016	WASHER, lock <i>(Primary assemblies only)</i>	5	▲			
156	24V745	SENSOR, level, low/empty	1	172	- - -	ARTWORK, instructions, wiring, ul	1
157	- - -	BUSHING, strain relief	1	181	- - -	FERRULE, wire, 10awg, twin <i>(Secondary assemblies only)</i>	3
158	- - -	NUT, bushing	1	182	17C669	CONNECTOR, jumper, male <i>(Secondary assemblies only)</i>	1
159	- - -	GROMMET, wire	1	183	123856	HARNESS, CAN, cable <i>(Secondary assemblies only)</i>	1
160	124654	CONNECTOR, splitter, 12(m) x m12(f) <i>(Secondary modules only)</i>	1	184	17C712	TOKEN <i>(Secondary assemblies only)</i>	1
161	121228	CABLE, can, female/female, 15.0 m <i>(Secondary modules only)</i>	1				
162	16W035	CONNECTOR, jumper <i>(8 zone assemblies only; Qty 1) (12 zone assemblies only; Qty 2)</i>					
163	- - -	CONTACT, socket, 20-24 awg, crimp, tin	3				

▲ Replacement Warning labels, signs, tags, and cards are available at no cost.

Electrical Panel

230V
400V/N
Transformer

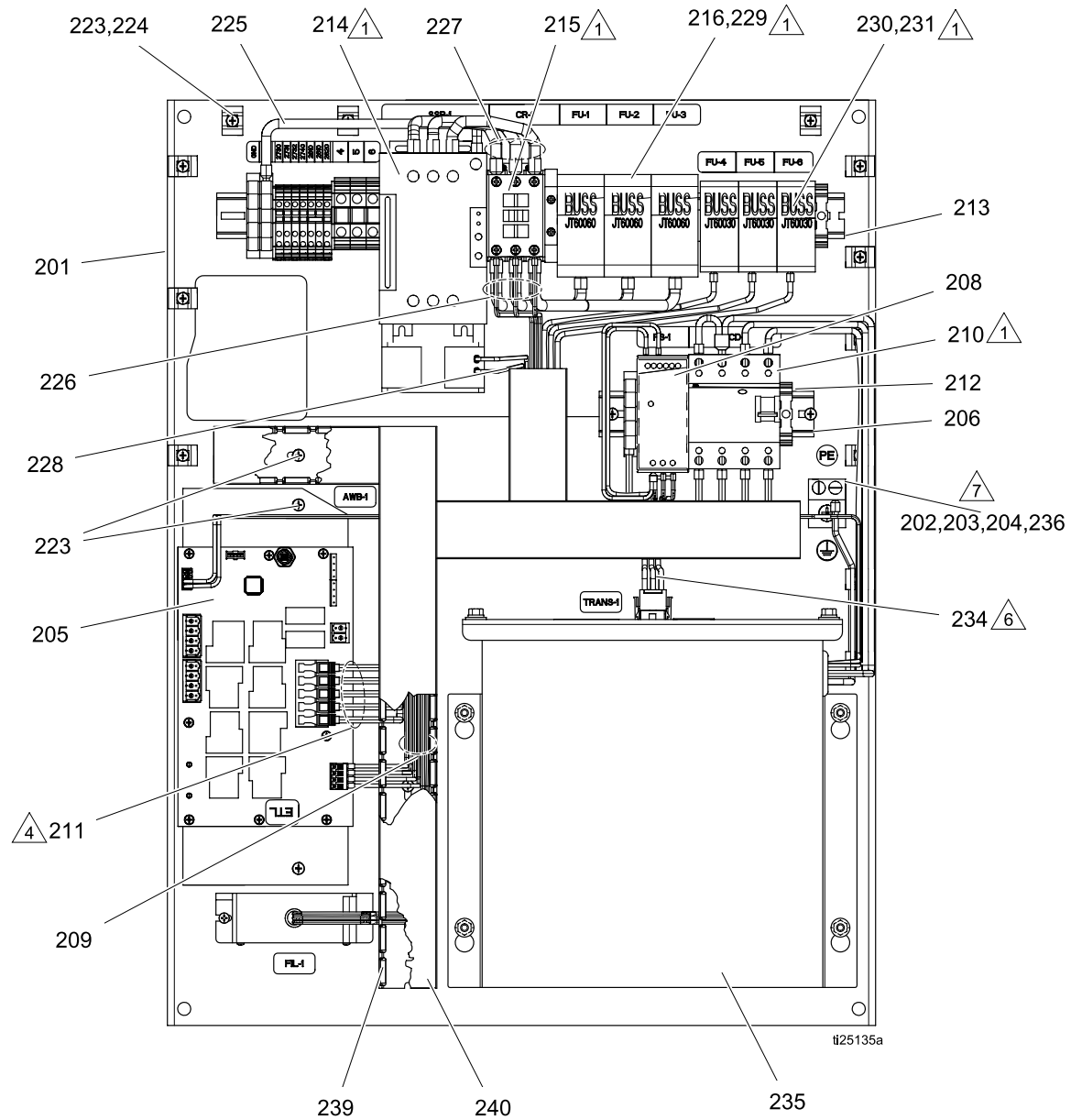

Transformer Panel Shown

- △₁ Torque terminals to 25–27 in-lbs (2.8–3.1 N•m).
- △₂ Torque terminals to 13.3–16 in-lbs (1.5–1.8 N•m).
- △₃ Torque terminals to 4.53–6.2 in-lbs (0.5–0.7 N•m).

Parts

230V Panel

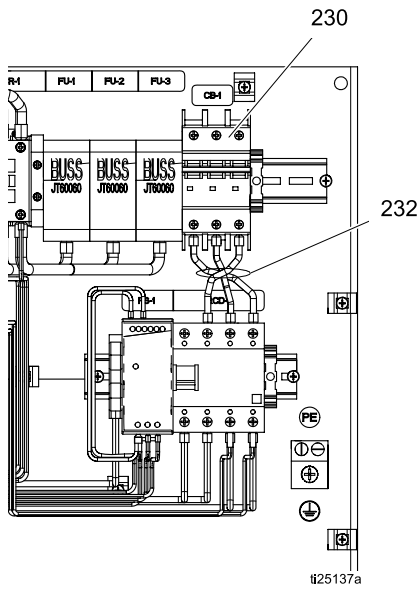

400V/N Panel

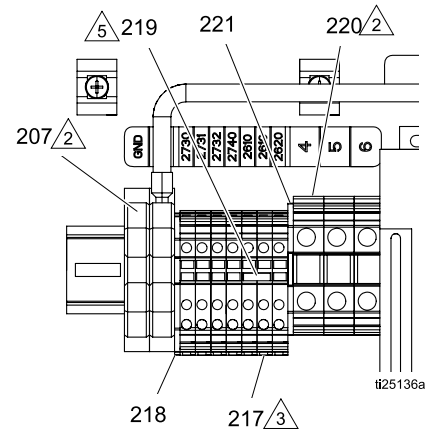
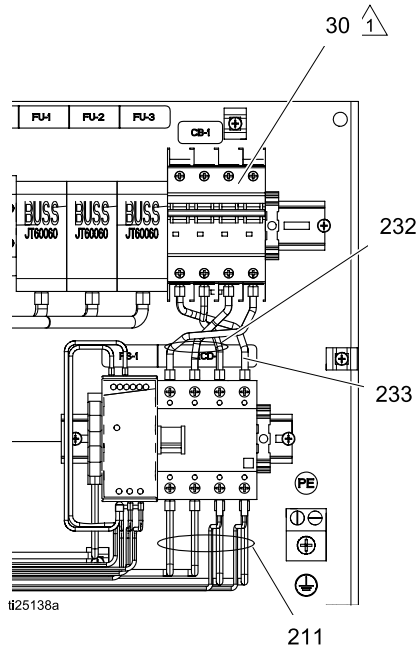

- △1 Torque terminals to 25–27 in-lbs (2.8–3.1 N•m).
- △2 Torque terminals to 13.3–16 in-lbs (1.5–1.8 N•m).
- △3 Torque terminals to 4.53–6.2 in-lbs (0.5–0.7 N•m).

Electrical Panel Parts

Ref.	Part	Description	Qty.	Ref.	Part	Description	Qty.
201	- - -	PANEL, elec, tof, 11ga, zinc	1	225	- - -	HARNESS, wire, ground, 8awg	1
202	117666	TERMINAL, ground	1	226	- - -	HARNESS, fuse, contactor	1
203	113783	SCREW, machine, pn hd	1	227	- - -	HARNESS, contactor, ssr	1
204	100985	WASHER, lock ext	1	228	- - -	HARNESS, rcd, ssr fan	1
205	24V816	MODULE, gca, awb	1	229	- - -	See Code C Table	3
206	- - -	RAIL, din, 6.5in	1	230	6690-24-164	FUSE, fuse block buss jt60030	3
207	123363	BLOCK, terminal, ground, 10mm	3	127744		CIRCUIT, breaker, 3p, 32a, ul489; <i>230V Panel only</i>	1
208	126453	POWER SUPPLY, 24v	1	127745		CIRCUIT, breaker, 20a, 4p, ul489; <i>400V Panel only</i>	1
209	- - -	HARNESS, power supply, awb	1	231	- - -	See Code C Table	3
210	128097	CIRCUIT, breaker, 63a, 4p, rcd	1	232	17A546	HARNESS, cb, rcd, 230-400V; <i>230V and 400V Panel only</i>	1
211	- - -	HARNESS, rcd, awb	1	233	17A558	HARNESS, cb, rcd, 400v/n; <i>400V Panel only</i>	1
212	126811	BLOCK, clamp end	2	234	17A541	HARNESS, fuses, transformer; <i>Transformer panel only</i>	1
213	- - -	RAIL, din, 19in	1	235	24V718	TRANSFORMER, multi-tap/230v, 6kva; <i>Transformer panel only</i>	1
214	120399	CONTROL, 65 amp, 120-600v	1	237	128014	FILTER, voltage, transient, 600V, 3P	1
215	123359	RELAY, contactor, 30a, 3p, 24vdc co	1	238	112380	SCREW, mach, pn hd	2
216	6690-24-165	FUSE, fuse block buss jt60060	3	239	81/0163-B/11	WIREWAY, panduit	4
217	128314	BLOCK, terminal 3-wire	7	240	81/0164-B/11	COVER, panduit	4
218	128321	COVER, end	1				
219	126819	BRIDGE, plug-in, 2-position	1				
220	127717	BLOCK, terminal, 2pos, ut16	3				
221	127718	COVER, end, ut16	1				
222▲	17C137	LABEL, multi safety	1				
223	103833	SCREW, mach, crbh	33				
224	123452	HOLDER, anchor, wire tie, nylon	12				

▲ Replacement Warning labels, signs, tags, and cards are available at no cost.

If Code A is 200 and Code E is M and Code C is			If Code A is 200 and Code E is F/S and Code C is		
Code C	(229)	(231)	Code C	(229)	(231)
X1X	24X885	NA	X1X	24X885	NA
X2X	24X885	NA	X2X	24X885	NA
X3X	24X881	24X878	X3X	24X880	24X878
X4X	24X882	24X877	X4X	24X881	24X877
X5X	24X884	24X874	X5X	24X883	24X874

Merkur 2200, 23:1 Pump Modules

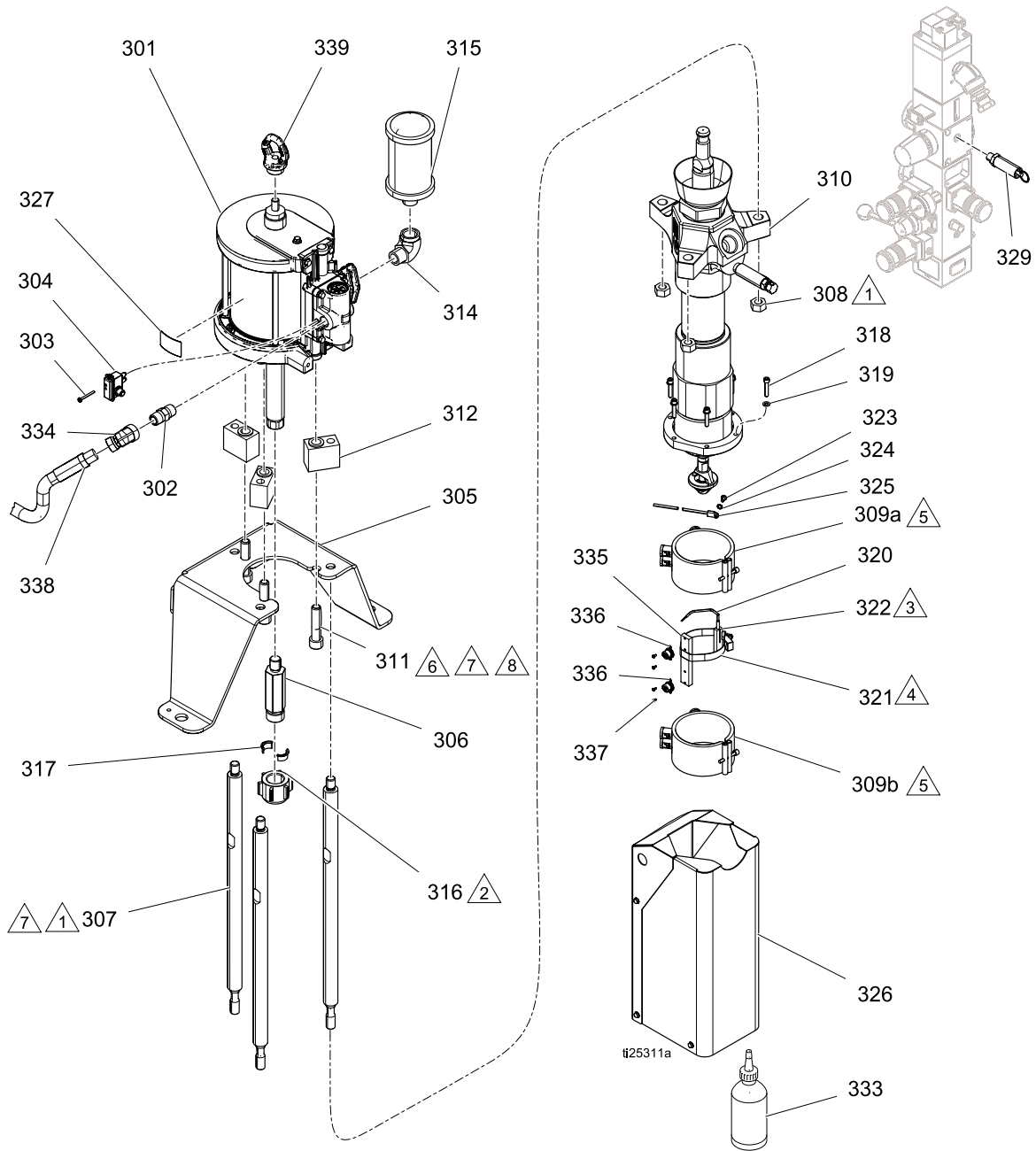

- △1 Torque to 50–60 ft-lb (68–81 n•m).
- △2 Torque to 145–155 ft-lbs (196–210 n•m).
- △3 Coat mounting surface of sensor mounting block with non-silicone heat sink compound. do not coat sensor.
- △4 Prior to tightening band clamp (321) RTD sensor (320) must be fully contained within the sensor mount (322).

- △5 Coat inside of heater (309a, 309b) only to within 3/4 in of vertical ends, with non-silicone heat sink compound before mounting.
- △6 Cap screws (311) must be loose while tie rods (307) are being torqued.
- △7 Torque to 150 ft-lbs (203 n•m).
- △8 Apply anaerobic sealant.

Merkur 2200, 23:1 Pump Modules

Ref.	Part	Description	Qty	Ref.	Part	Description	Qty
301	24W754	MOTOR, air, 6.0in, 4.75 strk, blue	1	321	C31012	CLAMP	1
302	C20485	FITTING, hex, nipple	1	322	C03507	SUPPORT, sensor	1
303	- - -	FASTENER, screw, slot hex, #8-32 tap	1	323	C38162	SCREW, machine	1
304	24X441	SWITCH, reed assy	1	324	C38163	WASHER, lock, ext. tooth	1
305	- - -	BRACKET, motor mount	1	325	- - -	CONDUCTOR, ground	1
306	15H397	ADAPTER, rod, pump	1	326	- - -	SHIELD, pump, tof20	1
307	16A223	ROD, tie, vert driver	3	329	103347	VALVE, safety, 100 psi	1
308	106166	NUT, mach ,hex	3	330	C33049	TAPE, adhesive, fiberglass	1.5
309	128322	HEATER, pump, 600 watt	2	331	- - -	LUBRICANT, high temp, thermal	1
310	24W152	PUMP, tof200, cf; 24V572 only	1	333	206994	FLUID, tsl 8 oz bottle	1
	24W153	PUMP, tof200, gf; 24V575 only	1	334	127766	FITTING, 45 elbow swivel, 1/2 npt(f) x 1/2 nps	1
311	109211	SCREW, cap, sch	3	365	127671	SWITCH, over temp, fixed, 450°F (232°C)	2
312	17A637	BLOCK, standoff, mounting	3	335	17B715	SUPPORT, block, overtemperature	1
315	102656	MUFFLER	1	336	127671	SWITCH, over temp, fixed, 450°F (232°C)	2
316	186925	NUT, coupling	1	337	122338	SCREW, cap, socket bh	4
317	184129	COLLAR, coupling	2	338	214656	HOSE, coupled	1
318	103345	SCREW, cap, sch	2	339	16C009	HOOK	1
319	100016	WASHER, lock	4				
320	17F009	SENSOR, RTD	1				

Merkur 3400, 36:1 Pump Modules

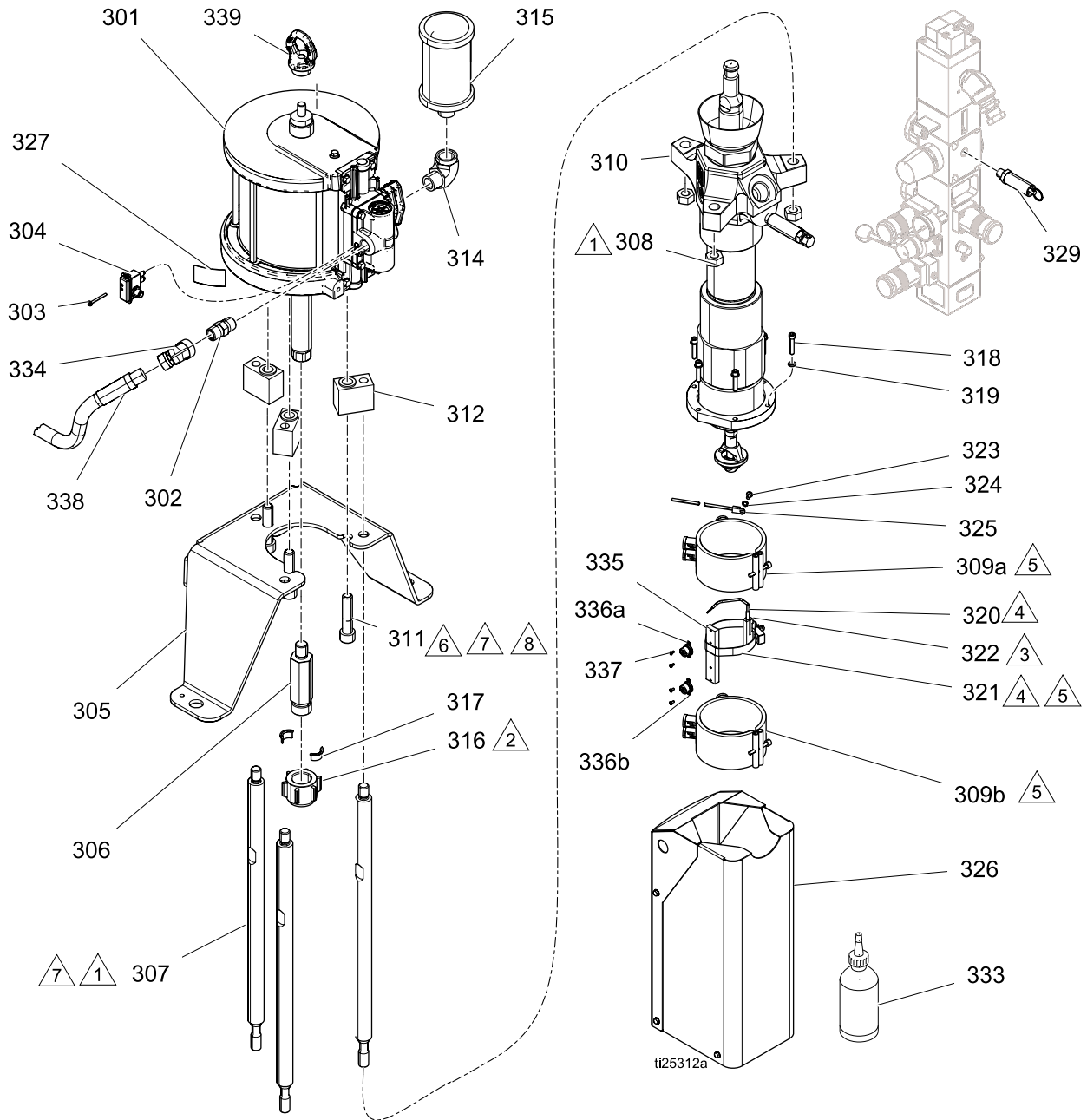

- △¹ Torque to 50–60 ft-lb (68–81 n•m).
- △² Torque to 145–155 ft-lbs (196–210 n•m).
- △³ Coat mounting surface of sensor mounting block with non-silicone heat sink compound. do not coat sensor.
- △⁴ Prior to tightening band clamp (321) RTD sensor (320) must be fully contained within the sensor mount (322).
- △⁵ Coat inside of heater (309a, 309b) only to within 3/4 in of vertical ends, with non-silicone heat sink compound before mounting.
- △⁶ Cap screws (311) must be loose while tie rods (307) are being torqued.
- △⁷ Torque to 150 ft-lbs (203 n•m).
- △⁸ Apply anaerobic sealant.

Merkur 3400, 36:1 Pump Modules

Ref.	Part	Description	Qty	Ref.	Part	Description	Qty
301	24R015	MOTOR, assy, air, 7.5in ,blue	1	320	17F009	SENSOR, RTD	1
302	C20485	FITTING, nipple, hex	1	321	C31012	CLAMP	1
303	- - -	FASTENER, screw, slot hex, #8-32 tap	1	322	C03507	SUPPORT, sensor	1
304	24X441	SWITCH, reed assy	1	323	C38162	SCREW, machine	1
305	- - -	BRACKET, motor mount, tof 200	1	324	C38163	WASHER, lock, ext. tooth	1
306	15H397	ADAPTER, rod, pump	1	325	- - -	CONDUCTOR, ground	1
307	16A223	ROD, tie, vert driver	3	326	- - -	SHIELD, pump	1
308	106166	NUT, mach ,hex	3	327	- - -	LABEL, identification	1
309	128322	HEATER, pump, 600 watt	2	329	103347	VALVE, safety, 100 psi	1
310	24W152	PUMP, tof20, long shaft, cf; 24V573 only	1	330	C33049	TAPE, adhesive, fiberglass; 1.5 ft (x m)	1
	24W153	PUMP, tof20, long shaft, gf; 24V576 only	1	331	- - -	LUBRICANT, high temp, thermal	1
311	109211	SCREW, cap, sch	3	333	206994	FLUID, tsl 8 oz bottle	1
312	17A637	BLOCK, standoff, mounting	3	334	127766	FITTING, 45 elbow, swivel, 1/2 npt(f) x 1/2 nps	1
315	102656	MUFFLER	1	335	17B715	SUPPORT, block, overtemp	1
316	186925	NUT, coupling	1	336	127671	SWITCH, over temp, fixed, 450°F (232°C)	2
317	184129	COLLAR, coupling	2	337	122338	SCREW, cap, socket bh	4
318	103345	SCREW, cap, sch	6	338	214656	HOSE, coupled	1
319	100016	WASHER, lock	6	339	16C009	HOOK	1

NXT 6500, 70:1 Pump Modules

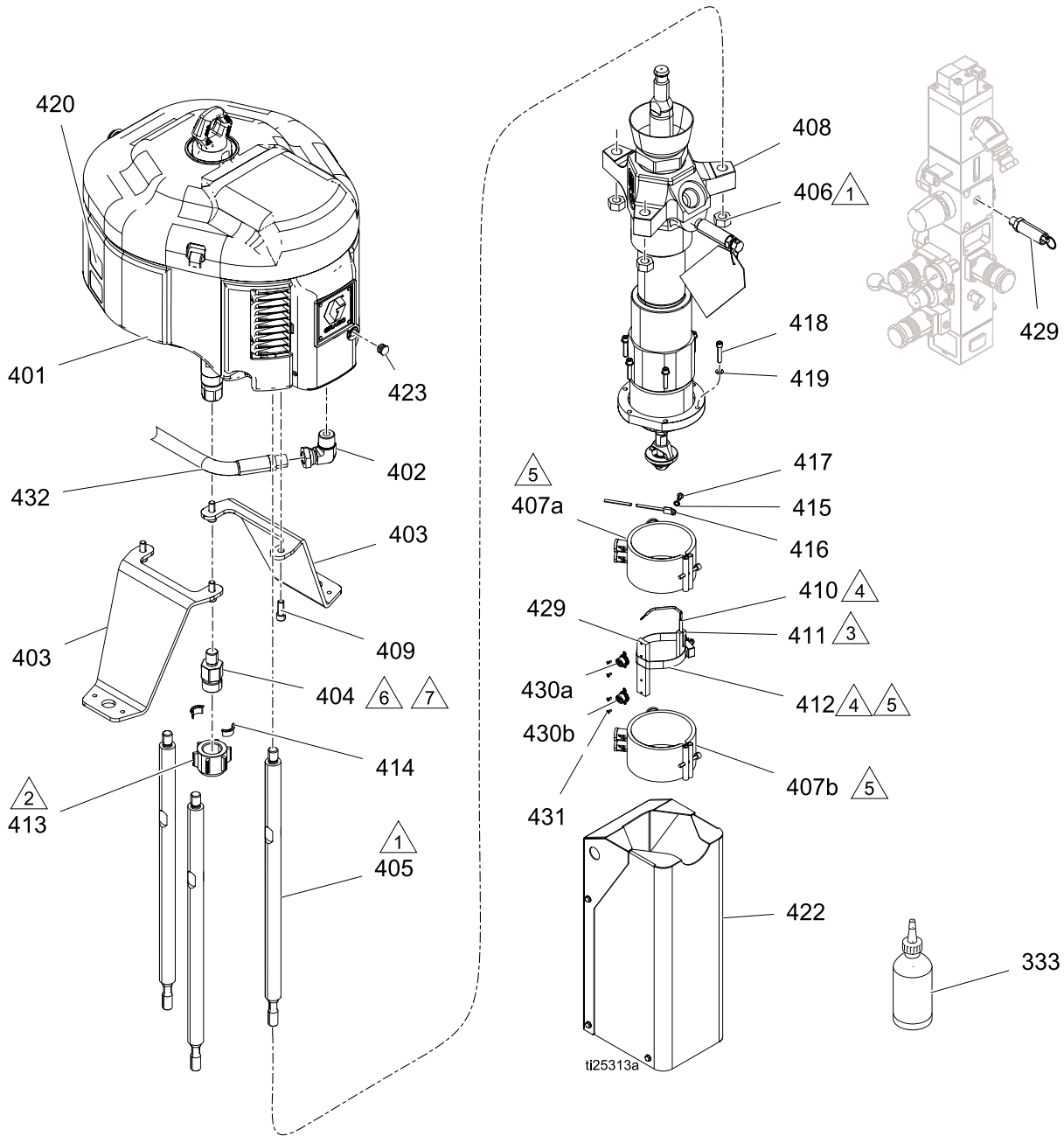

- △1 Torque to 50–60 ft-lb (68–81 n•m).
- △2 Torque to 145–155 ft-lbs (196–210 n•m).
- △3 Coat mounting surface of sensor mounting block with non-silicone heat sink compound. do not coat sensor.
- △4 Prior to tightening band clamp (412) rtd sensor (410) must be fully contained within the sensor mount (411).
- △5 Coat inside of heater (407a, 407b) only to within 3/4 in of vertical ends, with non-silicone heat sink compound before mounting.
- △6 Torque to 150 ft-lbs (203 n•m).
- △7 Apply anaerobic sealant.

NXT 6500, 70:1 Pump Modules

Ref.	Part	Description	Qty	Ref.	Part	Description	Qty
401	N65LR0	MOTOR, 6500, low-noise, remote	1	415	C38163	WASHER, lock, ext. tooth	1
402	120375	ADAPTER, elbow, 3/4 NPTI x 1/2 NPTE	1	416	- - -	CONDUCTOR, ground	1
403	15J288	BRACKET, mounting, motor, tof20	2	417	C38162	SCREW, machine	1
404	17A406	ADAPTER, rod, pump, tof	1	418	103345	SCREW, cap, sch	6
405	16A223	ROD, tie, vert driver	3	419	100016	WASHER, lock	6
406	106166	NUT, mach, hex	3	420	- - -	LABEL, ID	1
407	128322	HEATER, pump, 600 watt	2	422	- - -	SHIELD, pump, tof20	1
408	24W152	PUMP, tof 20, cf; 24V574 only	1	423	120588	PLUG, pipe, round	1
	24W153	PUMP, tof 20, gf; 24V577 only	1	424	120012	VALVE, safety, 50 psi	1
409	C19837	SCREW, cap, socket hd	4	425	- - -	LUBRICANT, high temp, thermal	1
410	17F009	SENSOR, RTD	1	426	C33049	TAPE, adhesive, fiberglass	1.5
411	C03507	SUPPORT, sensor	1	428	206994	FLUID, tsl 8 oz bottle	1
412	C31012	CLAMP	1	429	17B715	SUPPORT, block, overtemp	1
413	186925	NUT, coupling	1	430	127671	SWITCH, over temp, fixed, 450	2
414	184129	COLLAR, coupling	2	431	122338	SCREW, cap, socket bh	4
				432	214656	HOSE, coupled	1

Pump Shield

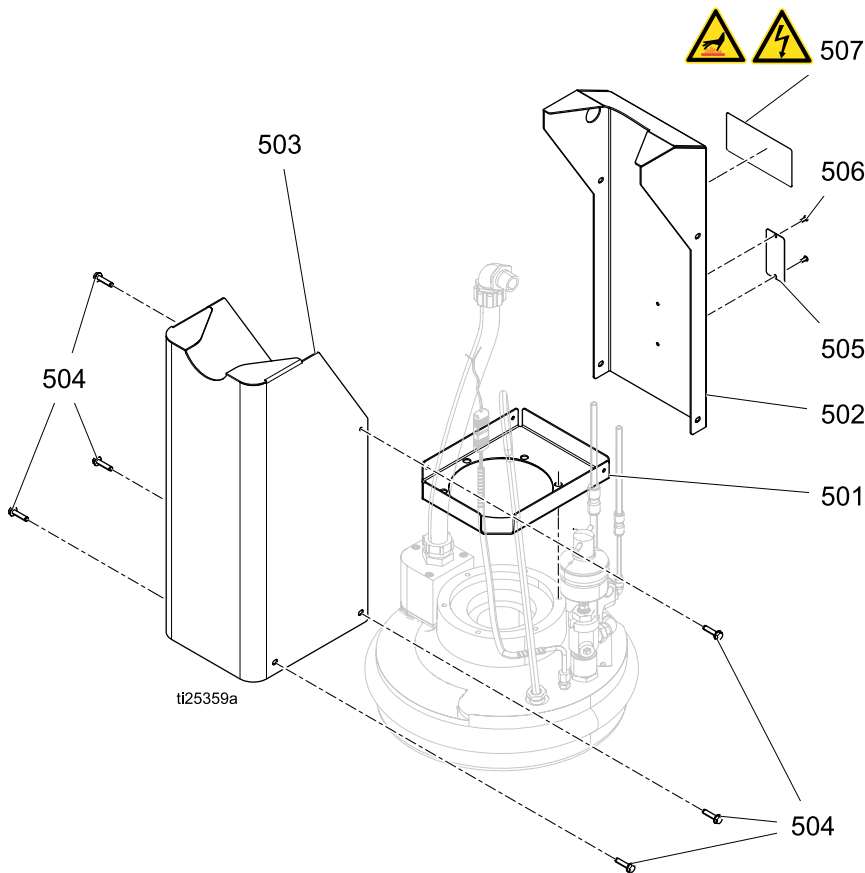

Ref	Part	Description	Qty	Ref	Part	Description	Qty
501	- - -	COVER, pump, bottom	1	505▲	184090	LABEL, warning	1
502	- - -	COVER, pump, back	1	506	104088	RIVET, blind	2
503	- - -	COVER, PUMP, front	1	507▲	15J075	LABEL, safety, hot surface and shock	1
504	C20474	SCREW, self-tapping	6				

▲ Replacement Warning labels, signs, tags, and cards are available at no cost.

President, 15:1 Pump Module

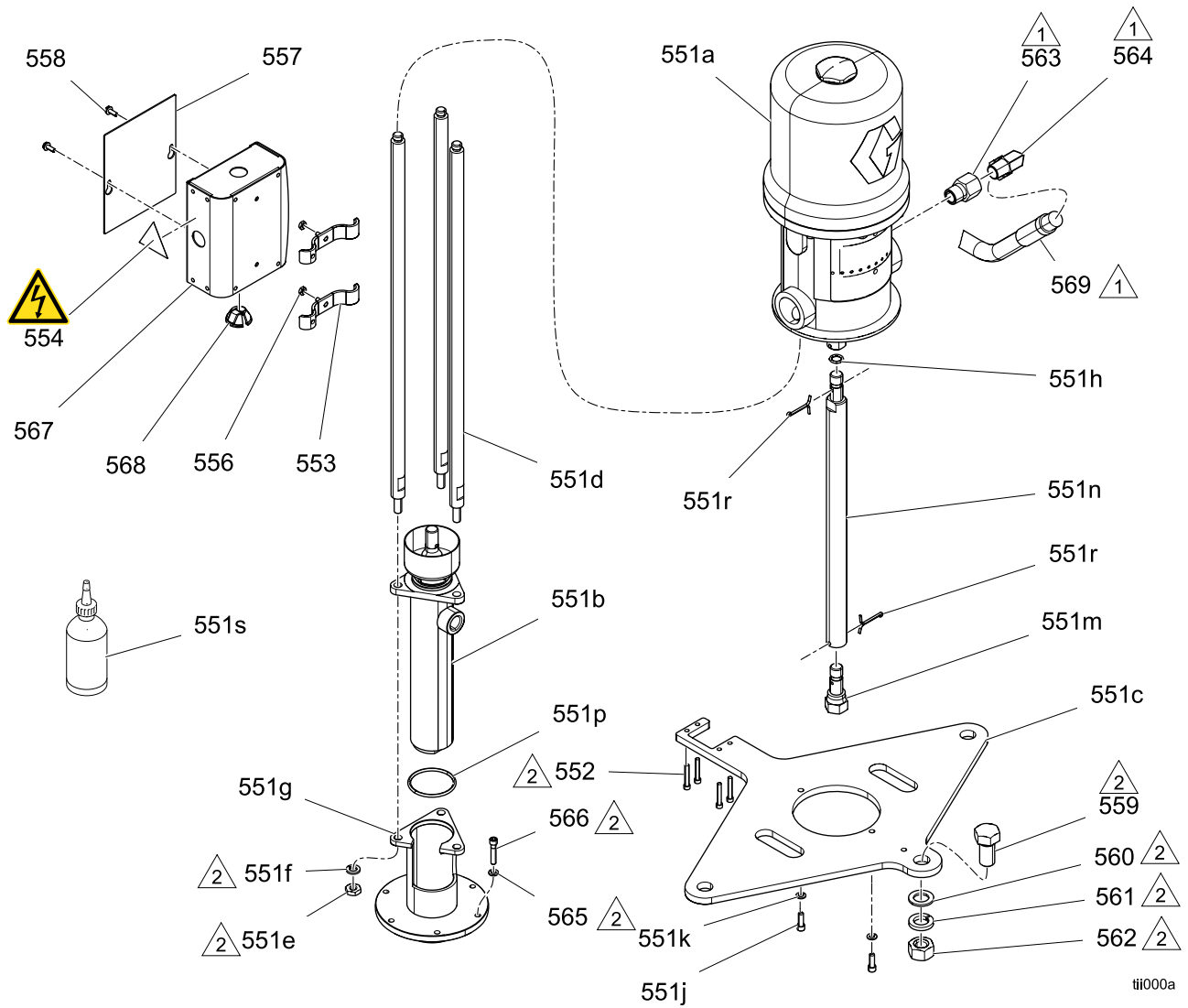

△₁ Torque to 20–30 ft-lb (27–41 N•m).

△₂ Torque to 30–40 ft-lbs (41–54 N•m).

iii000a

Parts

Ref.	Part	Description	Qty	Ref.	Part	Description	Qty
551	288505	PUMP, president	1	555	100020	WASHER, lock	2
551a	24B229	MOTOR, AIR, president	1	556	100179	NUT, hex mscr	2
551b	- - -	PUMP, hot melt mini-5	1	557	- - -	JUNCTION BOX, front cover	1
551c	- - -	PLATE, president mounting	1	558	- - -	FASTENER, thread-cutting screw	2
551d	198369	ROD, standoff	3	559	516587	BOLT, 3/4-10 x 1.5 hex head	1
551e	100340	NUT	3	560	154628	WASHER	2
551f	100133	WASHER, lock, 3/8	3	561	101015	WASHER,lock	1
551g	298073	ADAPTER, pump	1	562	C19187	NUT, hex	1
551h	156082	PACKING, o-ring, 112	2	563	- - -	ADAPTER	1
551j	112166	SCREW, cap, sch	2	564	155470	FITTING, swivel, union, 90 degree	1
551k	100016	WASHER, lock	2	565	100016	WASHER, lock	6
551m	207370	ROD, connecting	1	566	103345	SCREW, cap sch	6
551n	198412	ROD, connecting	1	567	- - -	JUNCTION BOX, main body	1
551p	C38225	PACKING, o-ring	1	568	127732	FITTING, 3/4" knockout, romex, pushin	1
551r	101946	PIN, cotter, sst	2	569	214656	HOSE, coupled, 61209, 10 ft	1
551s	206994	FLUID, TSL, 8 oz	1				
552	112756	SCREW, cap, socket hd	4				
553	- - -	BRACKET, mounting, junction box,	2				
554▲	196548	LABEL, warning, shock	1				

▲ *Replacement Warning labels, signs, tags, and cards are available at no cost.*

Heated Platens

24V742, Heated Drum Platen, Smooth Bottom (Code E- option S)

24V743, Heated Drum Platen, Standard Finned Bottom (Code E- option F)

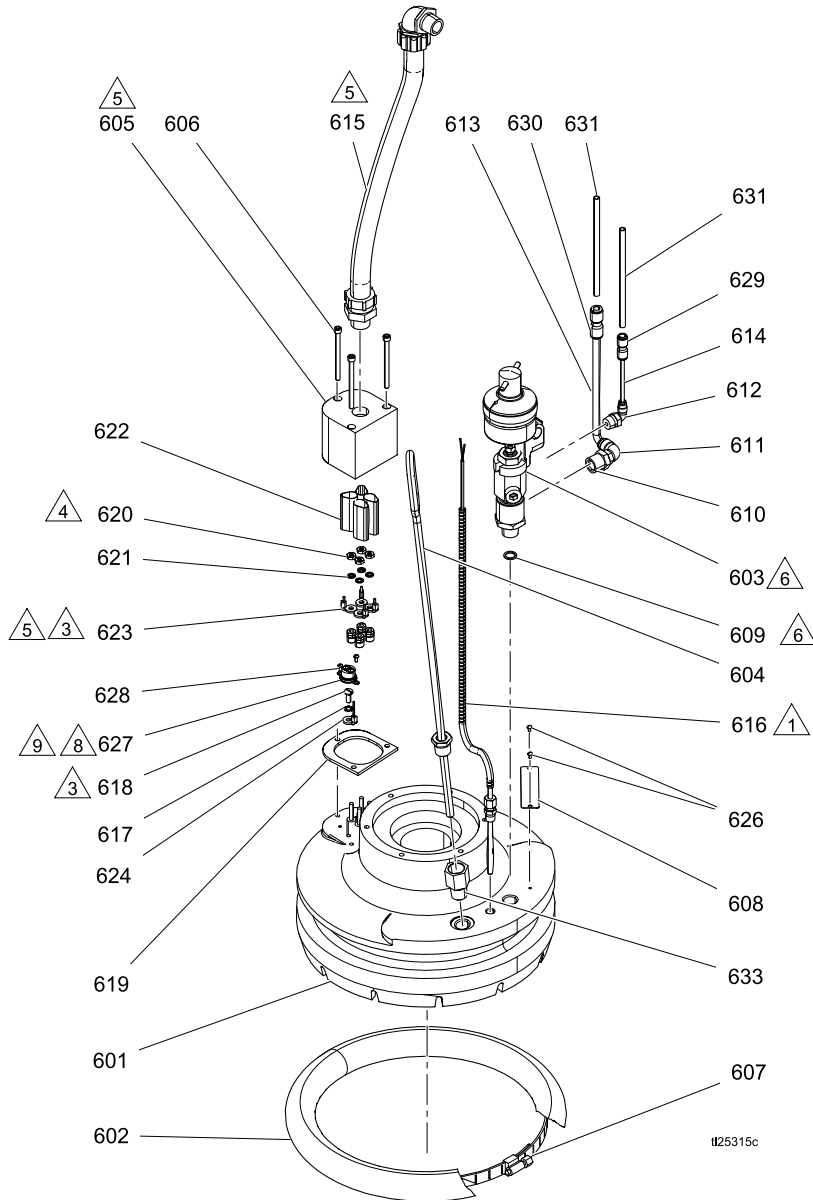

- △1 Coat RTD sensor (616) with non-silicone heat sink compound. Coat from tip to 1 in from tip.
- △3 Label cables for identification. See Cable Identification
- △4 Do not tighten heater terminal nuts down onto ceramic insulators to prevent damage.

- △8 Coat bottom of overtemperature switch (627) with non-silicone heat sink compound.
- △9 Label the wires on overtemperature switch (627) 2732, 2740 at the opposite end of the sensor.

Parts

Ref	Part	Description	Qty	Ref	Part	Description	Qty
601		PLATEN — see table below	1	617	C38163	WASHER, lock, ext. tooth	1
602★	C31052	HOSE, seal, Mini - 5	1	618	C19049	SCREW, mach, slotted, rnd hd	1
603	207440	VALVE, dispenser	1	619	15C171	GASKET	1
604	24X439	HANDLE, bleed	1	620	102931	NUT, mach. hex	4
605	- - -	ADAPTER, bushing	1	621	- - -	WASHER, lock, internal tooth	4
606	514930	SCREW, cap, skt hd	3	623	- - -	CONDUCTOR, heater	4
607★	C31154	CLAMP, worm gear	2	624	- - -	CONDUCTOR, ground	1
608	- - -	PLATE, designation	1	626	100508	SCREW, drive	2
609	167730	GASKET, copper	1	627	127671	SWITCH, overtemp, fixed	1
610	100176	BUSHING, hex	1	628	122338	SCREW, cap, socket, bh	2
611	115948	ELBOW, 1/4 npt(m), 5/16 OD tube	1	629	127689	FITTING, adapter, 1/4 in x 5/32 in tube	1
612	115949	ELBOW, 1/4npt(m), 5/32 OD tube	1	630	127690	FITTING, adapter, 5/16 in tube x 1/4 in tube	1
613	- - -	TUBE, PTFE, 1/4 x 5/16; 14 ft (4.2 m)	1	631	054130	HOSE, tubing; 1/4 in OD; 17 ft (5 m)	1
614	- - -	TUBE, PTFE, 3/32 x 5/32; 14 ft (4.2 m)	1	632	- - -	LUBRICANT, high temperature, thermal	1
615	- - -	CONDUIT, hi-temp, w/ fittings	1	633	150286	ADAPTER	1
616	128599	SENSOR, RTD, 5", 100 ohms, with heat shrink	1				

★ *Parts included in Seal Kit C31065 (purchase separately).*

Platen Model	Plate (601) Description	Qty.	Element Resistance
24V742	Standard Finned	1	28.8 ohms +3/-4
24V743	Smooth Bottom	1	28.8 ohms +3/-4

Accessories and Kits

Wiper Kits

Part No.	Description
C31065	Seal Kit

Applicators and Dispense Valves

Part No.	Description
249515	Manual Gun, Top Feed, 240V
249514	Manual Gun, Bottom Feed, 240V
249513	Manual Gun, Top Feed, Electric Switch, 240V
249512	Manual Gun, Bottom Feed, Electric Switch, 240V

Air-Operated Heated Dispense Valves

Part No.	Description
243694	Automatic Dispense Valve, 240V, Air-Operated Heated Dispense Valve
244951	Automatic Endure Dispense Valve, 240V, Air-Operated High Flow Heated Dispense Valve
244909	Automatic Endure Dispense Valve, 240V, Air-Operated Snuff-Back Heated Dispense Valve
243701	45 in (114 cm) Distribution Header With Valve, 240V

Flow Control and Manifolds

Part No.	Description
243700	Heated Air Operated Mastic Pressure Regulator, 240V
243656	23:1 Heated Pressure Compensator Valve, 240V

Part No.	Description
243657	51:1 Heated Pressure Compensator Valve, 240V
243697	Heated Distribution Manifold, 240V <i>Includes (2) 3/4 npt(f) inlet check valves, (1) npt 4–ported manifold, (2) 1 in npt(f) outlet gate valves, mounting bracket, 400w 230 VAC heaters, RTD sensor, and 8 pin connector box.</i>
289208	Compact Heated Regulator

Accessory Extension Cables

Use to connect fluid control devices and heated hoses to the electrical control enclosure.

Part No.	Description
Connect between controller and heated hose	
196313	15 ft, 16 pin to 16 pin
196314	25 ft, 16 to 16 pin
Connect between controller and heated accessory	
196315	15 ft, 16 pin to 8 pin
196316	25 ft, 16 pin to 8 pin
Connect between controller and heated devices	
196317	15 ft, 16 pin to (2) 8 pin
196318	25 ft, 16 pin to (2) 8 pin

Light Tower Kit, 24W589

Tie Rod Kits

Use to retrofit Check-Mate 800 Displacement Pump to an existing Therm-O-Flow system.

Part No.	Description
24V750	Bulldog® and Senator® Tie Rod Kit; see manual 334131
24V754	NXT® Tie Rod Kit; see manual 334132

Heated Hoses and Fittings

Hose Diameter	- 6 (9/16 in -18 JIC)	- 8 (3/4 in -16 JIC)	- 10 (7/8 in -14 JIC)	- 12 (1-1/16 in -12 JIC)	- 16 (1-5/16 in -12 JIC)	- 20 (1-5/8 in -12 JIC)
Hose Length						
3 ft (1.5 m)	None	None	None	15C586	None	None
6 ft (1.8 m)	None	115902	115875	None	115884	None
10 ft (3 m)	16J875	115873	115876	115880	115885	117821
15 ft (4.6 m)	None	115874	115877	115881	115886	117822
20 ft (6 m)	None	None	115878	115882	115887	None
25 ft (7.6 m)	None	None	115879	115883	115888	None
30 ft (9 m)	None	None	121200	None	None	None
Pump Fittings						
TOF 20/200 PUMP 1-11 1/2 DUAL OUTLET ADD 120263	16V432 100380	253267	253268	120260	120261	120262
TOF MINI 5 PUMP 1/2 NPT DUAL OUTLET ADD 120241	16V432	C20678	C20679	C38006	158586	120804 120268
Hose to Hose Fittings						
-6 Hose (.308 ID)	125779	123684	123683	123683 120265	123683 120265 120267	None
-8 Hose (.401 ID)	123684	120241	120242	120244	120244 120267	6308-82 126521
-10 Hose (.495 ID)	123683	120242	120243	120246	120246 120267	6308-82 126521
-12 Hose (.617 ID)	123683 120265	120244	120246	120247	120248	123135 126521
-16 Hose (.687 ID)	123683 120265 120267	120244 120267	120246 120267	120248	120249	120249 120268
-20 Hose (1.125 ID)	None	6308-82 126521	120246 120267 120268	123135 126521	120249 120268	120250

Hose Diameter	- 6 (9/16 in -18 JIC)	- 8 (3/4 in -16 JIC)	- 10 (7/8 in -14 JIC)	- 12 (1-1/16 in -12 JIC)	- 16 (1-5/16 in -12 JIC)	- 20 (1-5/8 in -12 JIC)
Fittings						
Compensator 51:1, 243657 Compensator 23:1, 243656 Inlet & Outlet: 1-11 1/2 in NPTF	16V432 100380	6308-82	123135 120266	123135	123854	15D936
Distribution manifold, 243697 Inlet: 3/4 in NPTF	16V432 100896	124286	15Y934	C20708	125661	125661 120268
Distribution manifold, 243697 Outlet: 1-11 1/2 in NPTF	16V432 100380	6308-82	123135 120266	123135	123854	15D936
Compact Heated Regulator, 289208 Inlet & Outlet: 3/8 in NPTF	16V432 100896	121311	116765	116766	116766 120267	116766 120267 120268
Mastic Regulator, 243700 Inlet & Outlet: 3/4 in NPTF	16V432 100896	124286	15Y934	C20708	125661	125661 120268
Top and bottom feed guns with and without switch, 249512, 249513, 249514, 249515 Inlet: 7/8-14 (JIC -10) male	117677	120264	None	120265	None	None
Standard, High Flow & Snuff-back Dispense valves, 243694, 244951, 244909 Inlet: 1/2 NPTF	16V432	124287	C20768	94/1027/99	125662	125662 120268
Distribution header, 243701 Inlet: 1/2 NPTF	16V432	124287	C20768	94/1027/99	125662	125662 120268
Precision Gear Meter PGM Inlet: 1-5/16-12 o-ring face seal	None	None	None	124238	124239	124240
Precision Gear Meter PGM Outlet: 3/4 NPTF	16V432 100896	124286	15Y934	C20708	125661	125661 120268
PCF Metering System Inlet & Outlet: 3/4 NPTF	16V432 100896	124286	15Y934	C20708	125661	125661 120268

8 Channel Upgrade Kit, 24V755

Use this kit to upgrade a 4 Channel system to a 8 channel system.

Ref	Part	Description	Qty	Ref	Part	Description	Qty
1		MODULE, GCA, MZLP	1	6	17A544	HARNESS, power, MZLP2, AWB	1
2	125856	SCREW, 8-32, serrated flange	4	7	112190	STRAP, wrist, grounding	1
3	16T440	CAP, souriau, UTS14	2	8	17C712	TOKEN, software upgrade	1
4	127511	CABLE, board, samtec	1	9	17C694	CABLE, TOF, LAPP to souriau	2
5	16W035	CONNECTOR, jumper	1				

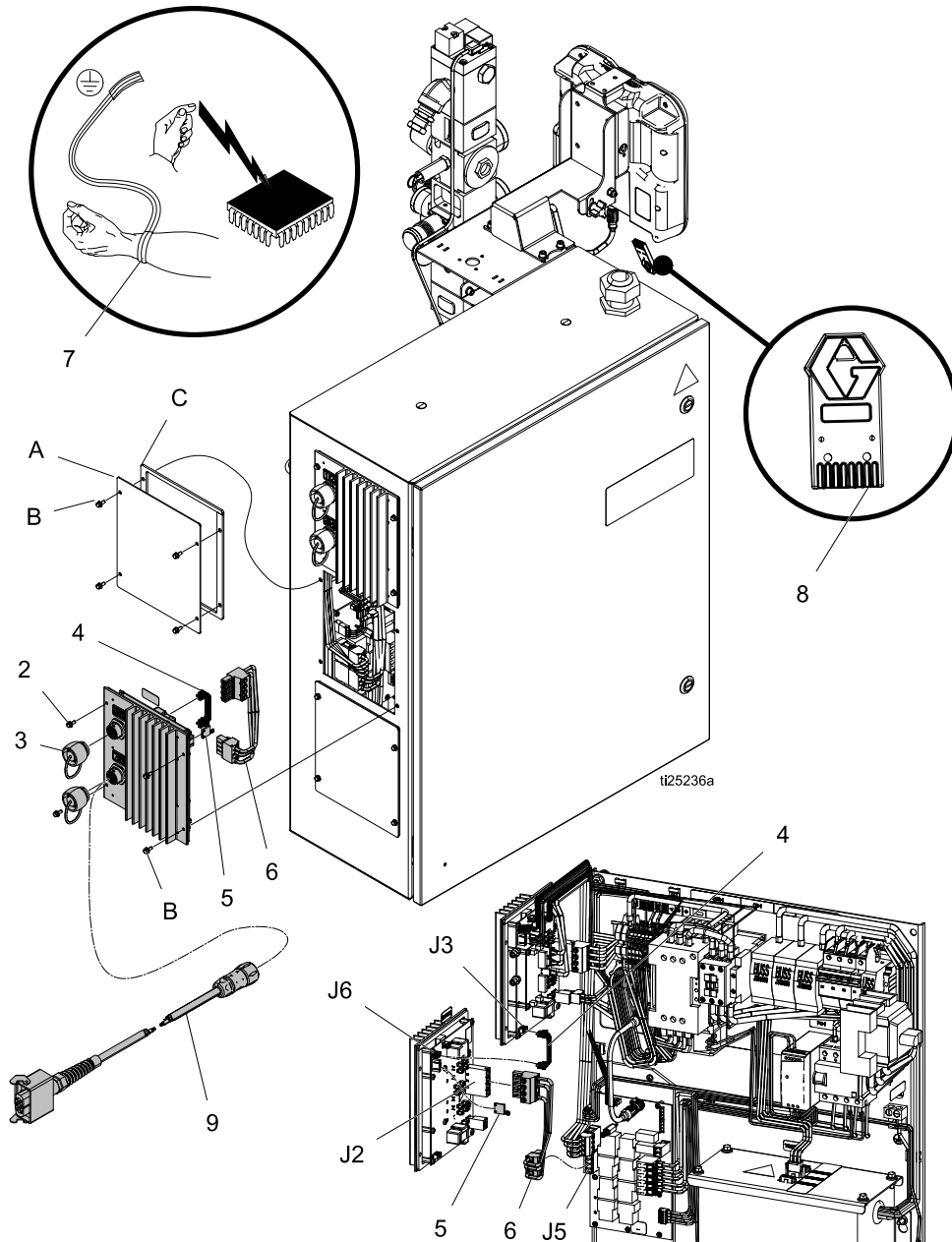

8 Zone Upgrade Kit Installation

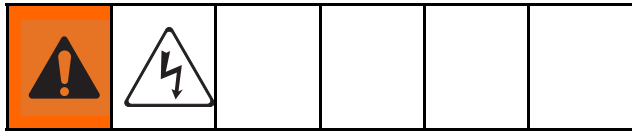

1. Disconnect plug from power outlet or turn off circuit breaker for incoming power.
2. Place grounding wrist strap (7) over your wrist and secure other end to a grounded surface.
3. Set the kit's MZLP (1) rotary switch to "2" on a primary system or "6" on a secondary system.
4. Remove screws (B), remove plate (A), and gasket (C) from system. Use screws (2) to install MZLP (1) onto system as shown.

Note

The new MZLP (1) will be referred to as MZLP 2, and the original MZLP that came with the system will be referred to as MZLP 1.

5. Open the electrical enclosure door.

Note

Do not force the electrical connection. Minimal force is required to seat the connector. If resistance is felt, stop, and verify the connector orientation.

6. Connect cable (4) to J3 connector on MZLP 1 and J6 connector on MZLP 2.
7. Connect power harness (6) to MZLP 2 connector J2 and J5 connector on AWB. Install jumper (5) on the MZLP 2 J5 connector
8. Use fittings and hoses that meet your hose routing needs. See [Accessories and Kits, page 87](#).
9. To ensure your system has the latest software, insert token (8) into the ADM. See [Update Software, page 59](#).

12 Channel Upgrade Kit, 24V756

Use this kit to upgrade a 8 channel system to a 12 channel system.

Ref	Part	Description	Qty	Ref	Part	Description	Qty
1		MODULE, GCA, MZLP	1	6	17A545	HARNESS, power, MZLP2/3, AWB	1
2	125856	SCREW, 8-32, serrated flange	4	7	112190	STRAP, wrist, grounding	1
3	16T440	CAP, souriau, UTS14	2	8	17C712	TOKEN, software upgrade	1
4	127511	CABLE, board, samtec	1	9	17C694	CABLE, TOF, LAPP to souriau	2
5	16W035	CONNECTOR, jumper	1				

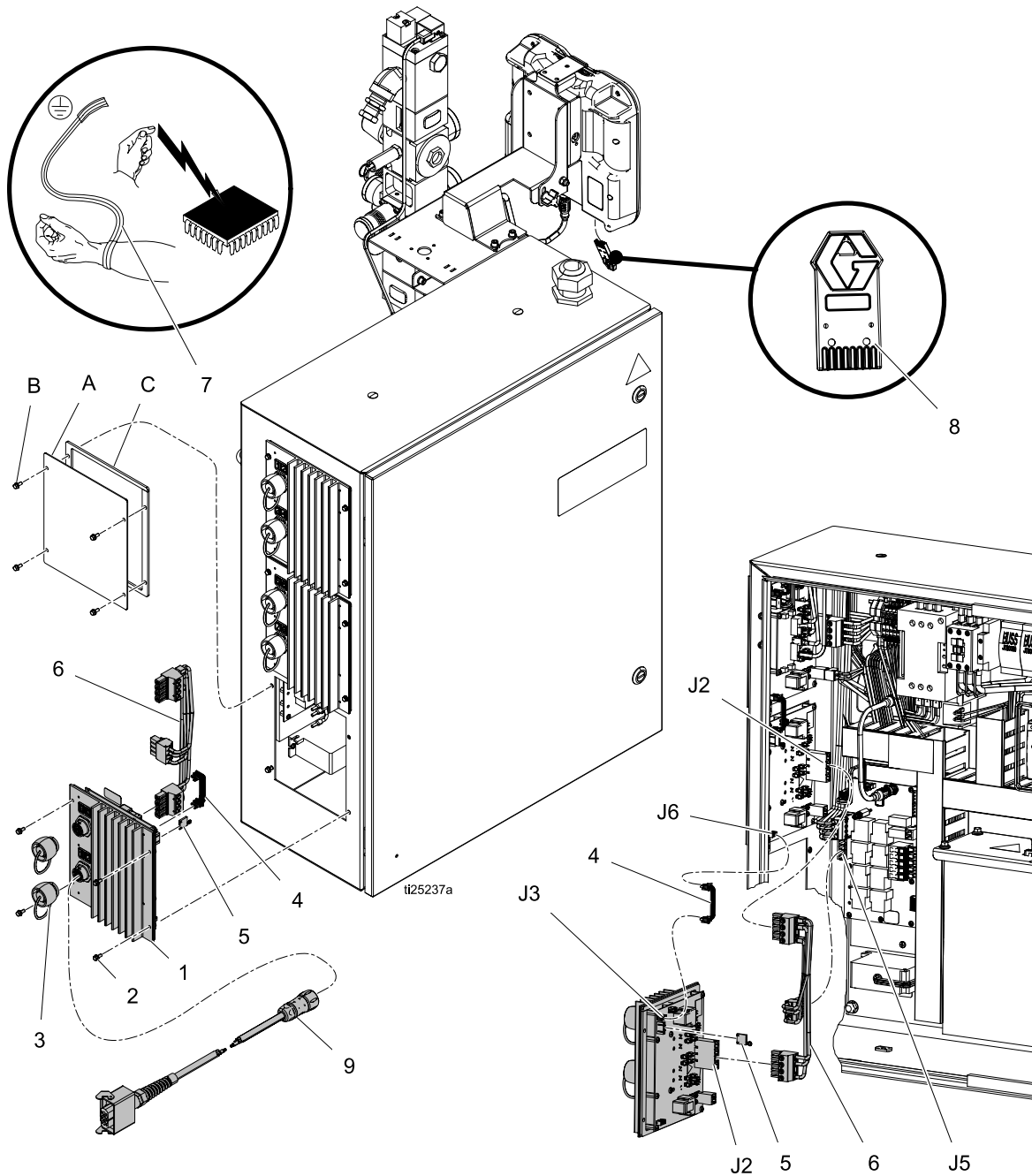

12 Zone Upgrade Kit Installation

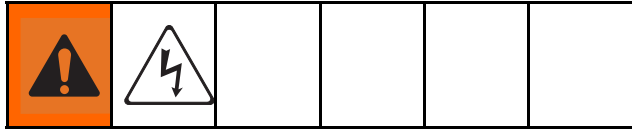

1. Disconnect plug from power outlet or turn off circuit breaker for incoming power.
2. Place grounding wrist strap (7) over your wrist and secure other end to a grounded surface.
3. Set the kit's MZLP (1) rotary switch to "3" on a primary system or "7" on a secondary system.
4. Remove screws (B), remove plate (A), and gasket (C) from system. Use screws (2) to install MZLP (1) onto system as shown.

Note

The new MZLP (1) will be referred to as MZLP 3, and the other two that came with the system will be referred to as MZLP 1 and MZLP 2.

5. Open the electrical enclosure door.

Note

Do not force the electrical connection. Minimal force is required to seat the connector. If resistance is felt, stop, and verify the connector orientation.

6. Connect cable (4) to J3 connector on MZLP 2 and J6 connector on MZLP (1). Remove existing power cable from MZLP 2 J2 and AWB J5 connector.
7. Connect power harness (6) to MZLP 2 and MZLP 3 J2 connector and J5 connector on AWB. Install
8. See [Install Heated Hose](#), to connect a heated hose or fluid control device.
9. To ensure your system has the latest software, insert token (8) into the ADM. See [Update Software, page 59](#).

Appendix A— ADM

General Operation

ADM Power

The ADM automatically turns on when the main power switch is turned on.

Screen Navigation

To switch between the Setup and Operation screens, press . Use the keypad to navigate between screens.















Enable, Disable Heating System

To enable or disable the entire heating system, press . To set which channels are active when the heating system is enabled, use the Heat-A and Heat-B Setup screens.

Icons













Screen Icons

These are frequently used icons on the screens. The following descriptions explain what each icon represents.

Icon	Description
	Primary System= A Secondary System = B
	Heating Disabled
	Warm Up, Actual temperature is outside of Target Temperature
	Reached Target Temperature
	Hose
	Gun
	Manifold
	PGM
	Flow Meter
	Pressure Regulator
	Other
	Advisory. See Error Codes for more information.
	Deviation. See Error Codes for more information
	Alarm. See Error Codes for more information

Softkey Icons

The following icons appear in the ADM, directly to the left or right of the soft key which activates that operation.

Icon	Function
	Pause Material Tracking
	Continue Material Tracking
	Pump Ready
	Setback
	Reset Cycle Counter (press and hold)
	Add or edit event
	Accept schedule
	Crossover for Tandem Systems
	Erase or cancel schedule
	Cancel
	Clear
	Schedule Event On/Off
	Heat On/Off

Operation Screens

Home

This screen shows the temperature state of the system and material usage.

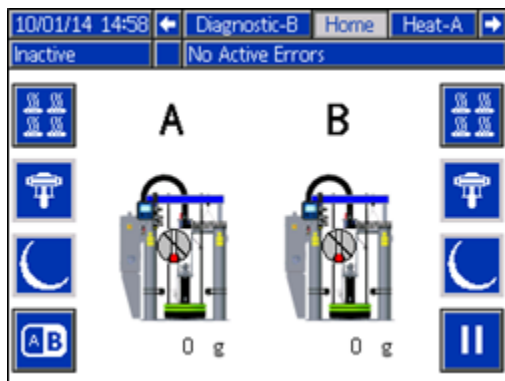

Note

If present, secondary systems will be shown on the home page.

Heat-A

This screen shows the target and actual temperatures for all zones on the system.

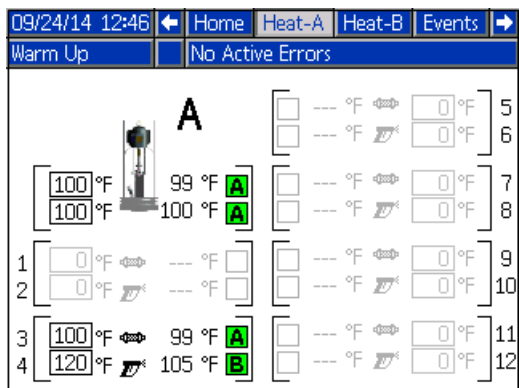

Note

The Heat-B screen shows information for an optional secondary system.

Color	A and B Zone Status
White	Off
Green	On and at setpoint temperature
Red	Outside of alarm range

Color	A and B Zone Status
Yellow	Outside of advisory range
Green/Yellow Flashing	Warmup

Events

The Events screens store a maximum of 200 events. The events list can be downloaded in the USB logs. See [Appendix B — USB Data, page 102](#).

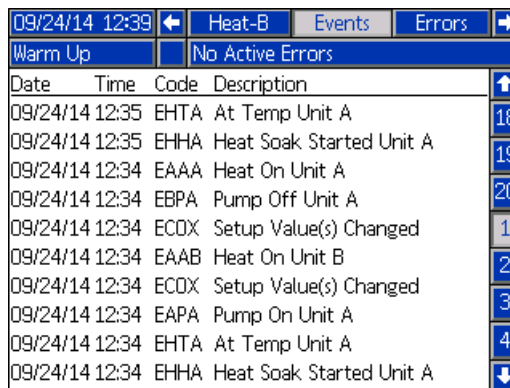

Tracked Events
Custom Language Downloaded
Custom Language Uploaded
Fill Valve Closed
Fill Valve Open
Heat Off
Heat On
Logs Downloaded
Pump Cycles Total Reset
Pump Off
Pump On
Red Stop Button Pressed
Setup Value Changed
System Power Off
System Power On
System Settings Downloaded
System Settings Uploaded
USB Disabled
USB Drive Inserted
USB Drive Removed
User Maintenance Count Reset

Errors

Date	Time	Code	Description
09/24/14	12:41		Warm Up
No Active Errors			
09/24/14	11:00	T3AE	High Temp. Platen
09/24/14	10:54	T3AE	High Temp. Platen
09/24/14	10:50	T6B3	Sensor Err. CH3 Zone
09/24/14	10:50	CAC4	Comm. Error MZLP 4
09/24/14	10:50	CACY	Comm. Error System I/O, Unit B
09/24/14	10:48	T6B3	Sensor Err. CH3 Zone
09/24/14	10:48	V8M4	No Voltage Line MZLP 4
09/24/14	10:48	L2BX	Drum Empty Unit B
09/24/14	10:48	CAC4	Comm. Error MZLP 4
09/24/14	10:47	CAC4	Comm. Error MZLP 4

The Errors screens store a maximum of 200 errors. See [Error Codes](#). Download the errors list in the USB logs. See [Appendix B — USB Data, page 102](#).

Diagnostic-A

09/24/14 12:55		Diagnostic-A		Home	
Heat Ready		No Active Errors			
Pump:	0.00 A	130.6 °F	0 %	ISO DI(0:3)	DI(0:3)
Platen:		121.3 °F	0 %	0000	0001
Zone 1:	0.00 A		0 %	ISO DO(0:3)	DO(0:3)
Zone 2:	0.00 A		0 %	1010	0000
Zone 3:	0.66 A	119.1 °F	4 %	Pump CPM	Pump Sol
Zone 4:	0.00 A		0 %	0	0.00 A
Zone 5:	0.00 A		0 %	Life Cycles	Weight
Zone 6:	0.00 A		0 %	0	0.0 g
Zone 7:	0.00 A		0 %	Heat Soak:	Fan
Zone 8:	0.00 A		0 %	0	0 mA
Zone 9:	0.00 A		0 %	MZLP 1	XFMRTemp
Zone 10:	0.00 A		0 %	84.7 °F	
Zone 11:	0.00 A		0 %	USB DL %	CAN
Zone 12:	0.00 A		0 %	0.0 %	22.596 V

A B C

This screen shows details of various items to aid in troubleshooting the system. This screen can be hidden by de-selecting “Enable Diagnostics Screen” on the System 3 screen. The flow rate updates every 15–20 seconds with average flow rate over the last 15–20 seconds.

Note

Diagnostic-B shows information for an optional secondary system.

The following information is displayed.

	Diagnostic Data
A	Current Draw
B	RTD Reading
C	Duty Cycle

CAN: 24 VDC power supply voltage reading (18–28 VDC)

DI: System Digital Inputs
 0: Drum Empty
 1: Drum Low
 2: Pump Cycle Switch Up
 3: Pump Cycle Switch Down

DO: System Digital Outputs
 0: Pump Solenoid
 1: Not Used
 2: Not Used
 3: Not Used

ISO DI: Customer Digital Inputs
 See [Connect PLC, page 27](#).

ISO DO: Customer Digital Outputs
 See [Connect PLC, page 27](#).

Fan: current to fan

Heat Soak: set time for platen to heat after the platen has reached set temperature.

Life Cycles: total number of pump cycles over life of system

MZLP 1: temperature on MZLP 1

- 32–160°F(0–71°C)

Pump Sol: Current draw of pump solenoid

- (0 mA - off)
- (150-250 mA - on)

Pump CPM: Pump cycles per minute.

USB DL%: Percentage complete, only applies when downloading USB data. 5 downloads will occur.

Weight: Weight of material dispensed over life of system

XFMRTemp: Temperature of transformer temperature sensor

Setup Screens

Note

It is important to set all settings in the System screens correctly to ensure optimal system performance.

Password

If the password is not “0000”, the password must be entered to access the setup screens.

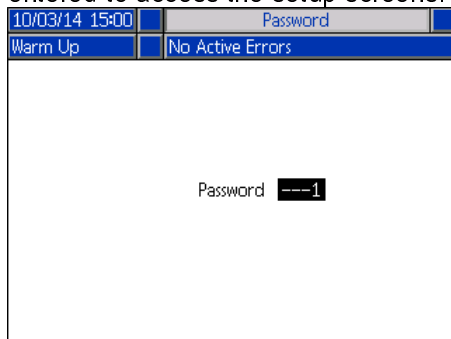

System 1

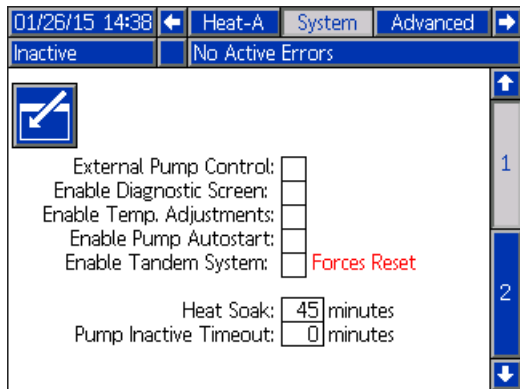

External Pump Control: Enable feature that automatically turns on and off the pump when using a handheld dispense gun with an integrated trigger switch.

Enable Diagnostic Screen: Choose whether to show the Diagnostic screen.

Enable Temp. Adjustments: Allows temperature adjustments on the Heat-A and Heat-B Run screens.

Enable Pump Autostart: Automatically turns the pump on after reaching setpoint temperature and heat soak is complete.

Enable Tandem System: Enable all secondary system ADM screens.

Heat Soak: Time for to preheat after all zones have reached their target temperatures. Pump cannot turn on until timer is complete. The heat soak is a user-defined time.

- Range: 0–120 minutes
- 0 disables heat soak

Pump Inactive Timeout: If no pump movement is detected or either pump for (x) amount of time, all heated zones enter setback mode. After an additional amount of time (x), the heat will turn off.

- (x) Range: 0–120 minutes
- 0 disables heat soak

System 2

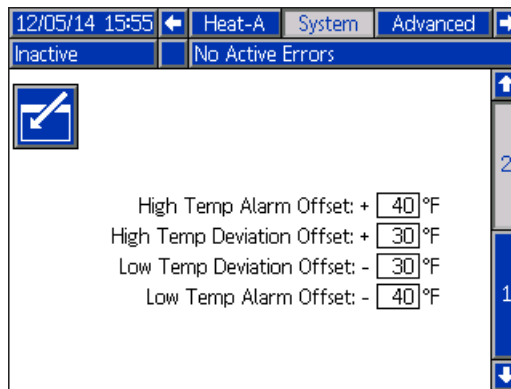

Enter low and high temperatures for an alarm or warning to occur.

Advanced 1

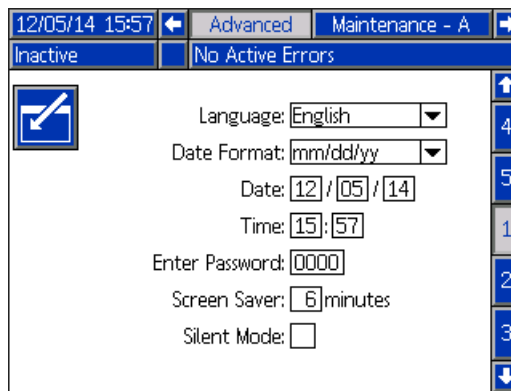

Language: Language displayed on the screen.

Date Format: Choose format of the date.

Date: Set the date.

Time: Set the time.

Enter Password: If not “0000”, the Setup screens will be password protected.

Screen Saver: The screen will go black after the set amount of time.

Silent Mode: Disable ADM sounds.

Advanced 2

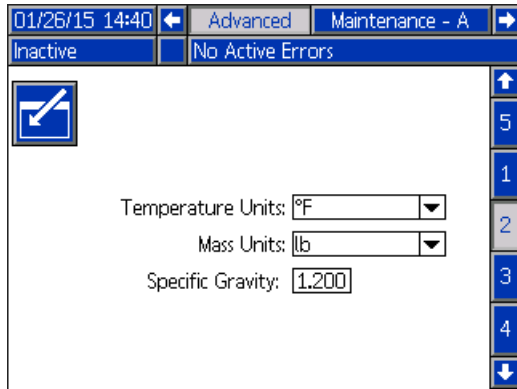

Temperature Units: Units of measure for displayed temperatures.

Mass Units: Units of measure for mass.

Specific Gravity: Required to convert the volume dispensed to mass dispensed for tracking the total weight and flow rate. When the specific gravity value is populated, the total mass dispensed since the last total weight reset is shown on the Home screen and the mass flow rate is shown on the Diagnostic screen.

Note

If the Specific Gravity is set to zero, the Home screen will display a cycle counter instead of grams or pounds.

Advanced 3

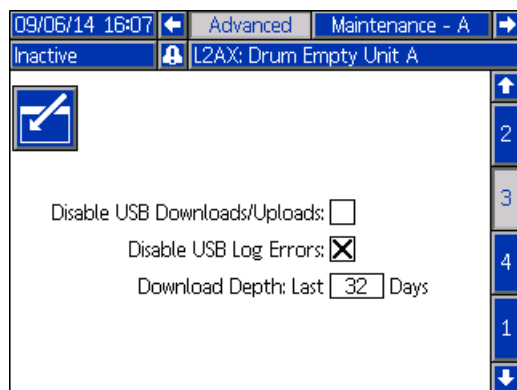

Disable USB Downloads/Uploads: Disables use of the USB for downloading and uploading.

Disable USB Log Errors: When disabled, the system will not warn the user when logs are full. If the logs are full, the oldest data will be overwritten.

Download Depth: Last ___ Days: The USB download will provide data as old as the number of days entered. Old data may be in memory but will not be downloaded if older than the number of days entered.

Advanced 4 and 5

Module	Software Part #	Software Version
Advanced Display	17C044	1.01.001
USB Configuration	17C049	1.01.001
AWB-A	16W672	1.03.003
Temperature Control Module 1	16T936	1.07.001
Temperature Control Module 2	16T936	1.07.001
Temperature Control Module 3	16T936	1.07.001

Module	Software Part #	Software Version
AWB-B	16W672	1.03.003
Temperature Control Module 5	16T936	1.07.001
Temperature Control Module 6	16T936	1.07.001
Temperature Control Module 7	16T936	1.07.001

Advanced 4 screen shows the part number and version of each installed software module on a primary unit and Advanced 5 shows each module on a secondary unit.

Heat-A

12/05/14 16:09		Schedule	Heat-A	System
Inactive	No Active Errors			
	A	Pump	380	300
		Platen	380	300
Zone Type			380	300
1	Hose		380	300
2	Gun		380	300
3	Hose		380	300
4	Gun		380	300

12/18/14 13:16		Schedule	Heat-A	Heat-B
Inactive	No Active Errors			
	Zone Type		380	300
5	Hose		380	300
6	Gun		380	300
7	Hose		380	300
8	Gun		380	300
9	Hose		380	300
10	Gun		380	300
11	Hose		380	300
12	Gun		380	300

Use these screens to set target and setback temperatures for the pump, platen, and zones. Select which system needs to use the heated accessory.

Zone Types:

- Hose
- Gun
- PGM
- Flowmeter
- Pressure Regulator
- Manifold
- Other

Note

To ensure accurate hose and gun temperatures, set hose as zone 1, 3, 5, 7, 9, or 11 when cable 17C694 is connected to MZLP and a heated hose.

Maintenance-A

09/06/14 16:12 Maintenance - A Schedule

Inactive L2AX: Drum Empty Unit A

Due Interval
User Cycles

Totalizers
Current Lifetime
Pump 0 Cycles
Weight g

The system will notify the user at the set interval that maintenance is required. The fields in boxes can be edited by the user. "Due" and "Current" are both the number of cycles since the last reset. "Interval" is the set number of cycles between maintenance notifications. "Lifetime" is the number of cycles in the lifetime of the system.

Note

The lifetime cycle count will only be reset if the ADM is replaced.

Schedule

09/06/14 16:14 Schedule Heat-A

Inactive L2AX: Drum Empty Unit A

	Mon	Tue	Wed	Thu	Fri	Sat	Sun
06:00	06:00	06:00					
14:00		11:00	11:00				
		12:00	12:00				
		16:00	16:00				

Use this screen to set times that the system will automatically enable and disable heating. See [Schedule, page 37](#) .

Appendix B — USB Data

The system can store 250,000 entries in its logs and the system adds a new entry to the logs every 15 seconds. This means the system stores 1041 hours of system operation data, or 43 days of around-the-clock operation. Once full, the system will overwrite the oldest data.

Note

To prevent losing any data, never go more than 43 days without downloading the logs.

Download

NOTICE

Uploading an edited system configuration file can damage the system. Never put a modified SETTINGS.TXT file in the UPLOAD folder on the flash drive.

Note

The event log, error log, system settings, and system language files are all downloaded in this procedure.

1. Insert USB flash drive into USB port.

Note

Flash drive must be 8 GB or smaller.

2. The menu bar and USB indicator lights indicate that the USB is downloading files. Wait for USB activity to complete. A pop-up will be present until the transfer is complete if it is not acknowledged.

Note

If the pop-up screen does not appear, the flash drive is not compatible with the ADM. Try a different flash drive.

Note

The system can log up to 45 mb of additional data per week, depending on system operation.

Access Files

All files downloaded from the USB are put in a DOWNLOAD folder on the stick drive. For example: "E:\GRACO\12345678\DOWNLOAD\". The 8-digit numeric folder name matches the 8-digit ADM serial number, which is located on the back of the ADM. When downloading from multiple ADMs, there will be one sub-folder in the GRACO folder for each ADM.

The log files should be opened in a spreadsheet program.

Note

If emailing the files, zip (compress) them to minimize file size.

Upload

Upload a system configuration file and/or a custom language file. See [System Settings File, page 103](#) or [System Language File, page 104](#).

1. If necessary, follow the [Download Instructions, page 102](#), to automatically generate the proper folder structure on the USB flash drive.
2. Insert USB flash drive into USB port of computer.
3. The USB flash drive window automatically opens. If it does not, open USB flash drive from within Windows Explorer.
4. Open Graco folder.
5. Open system folder. If working with more than one system, there will be more than one folder within the Graco folder. Each folder is labeled with the corresponding serial number of the ADM. (The serial number is on the back of the module.)
6. *If installing the system settings file*, place SETTINGS.TXT file into UPLOAD folder.
7. *If installing the custom language file*, place DISPTXT.TXT file into UPLOAD folder.
8. Remove USB flash drive from computer.
9. Install USB flash drive into Therm-O-Flow system USB port.
10. The menu bar and USB indicator lights indicate that the USB is uploading files. Wait for USB activity to complete.
11. Remove USB flash drive from USB port.

Note

If a custom language file was installed, users can now select the new language from the Language drop-down menu.

Note

If the SETTINGS.TXT or DISPTXT.TXT files remain in the UPLOAD folder, they will be uploaded every time the USB drive is inserted into the corresponding ADM. To avoid unintentionally overwriting system settings, delete the files from the UPLOAD folders on the USB drive after the upload is complete.

USB Logs

During operation, the Therm-O-Flow stores system and performance related information to memory in the form of log files. The Therm-O-Flow maintains the events, data, GCA, Black Box, and Diagnostics logs. Follow the **Download Procedure**, to retrieve log files.

Events Log

The event log (1-EVENT.CSV) maintains a record of the last 175,000 events. Each event record in the log file contains the date and time the event occurred, the event type, event code, and event description.

Data Log

The data log (2-DATA.CSV) tracks the setpoint and actual temperatures every 15 seconds. This log can store up to 250,000 lines of data.

The system stores 1041 hours of system operation data, or 43 days of around-the-clock operation. Once full, the system will overwrite the oldest data.

Change Log

The change log (3-CHANGE.CSV) tracks the changes to setpoint and setback temperatures.

GCA Log

This log (4-GCA.CSV) lists the installed GCA modules and their respective software versions.

Black Box, Diagnostics Log

These logs (5-BLACKB.CSV, 6-DIAGN.CSV) are designed to provide useful information to Graco when calling for technical assistance.

System Settings File**NOTICE**

Uploading an edited system configuration file can damage the system. Never put a modified SETTINGS.TXT file in the UPLOAD folder on the flash drive.

The system configuration settings file name is SETTINGS.TXT and is stored in the DOWNLOAD folder.

A system configuration settings file automatically downloads each time a USB flash drive is inserted. Use this file to back up system settings for future recovery or to easily replicate settings across multiple Therm-O-Flow systems. Refer to the [Upload Instructions, page 102](#), for how to use this file.

It is recommended to retrieve the SETTINGS.TXT file after all system settings are set as desired. Store the file for future use as a backup in case the settings are changed and need to be quickly changed back to the desired setup.

Note

System settings may not be compatible between different versions of the Therm-O-Flow software.

System Language File

The system language file name is DISPTXT.TXT and is stored in the DOWNLOAD folder.

A system language file automatically downloads each time a USB flash drive is inserted. If desired, use this file to create a user-defined set of custom language strings to be displayed within the ADM.

The system is able to display the following Unicode characters. For characters outside of this set, the system will display the Unicode replacement character, which appears as a white question mark inside of a black diamond.

- U+0020 - U+007E (Basic Latin)
- U+00A1 - U+00FF (Latin-1 Supplement)
- U+0100 - U+017F (Latin Extended-A)
- U+0386 - U+03CE (Greek)
- U+0400 - U+045F (Cyrillic)

Create Custom Language Strings

The custom language file is a tab-delimited text file that contains two columns. The first column consists of a list of strings in the language selected at the time of download. The second column can be used to enter the custom language strings. If a custom language was previously installed, this column contains the custom strings. Otherwise the second column is blank.

Modify the second column of the custom language file as needed and then follow the [Upload Instructions, page 102](#), to install the file.

The format of the custom language file is critical. The following rules must be followed in order for the installation process to succeed.

1. The file name must be DISPTXT.TXT.
2. The file format must be a tab-delimited text file using Unicode (UTF-16) character representation.
3. The file must contain only two columns, with columns separated by a single tab character.
4. Do not add or remove rows to the file.
5. Do not change the order of the rows.
6. Define a custom string for each row in the second column.

Dimensions

Ram Mounting and Clearance

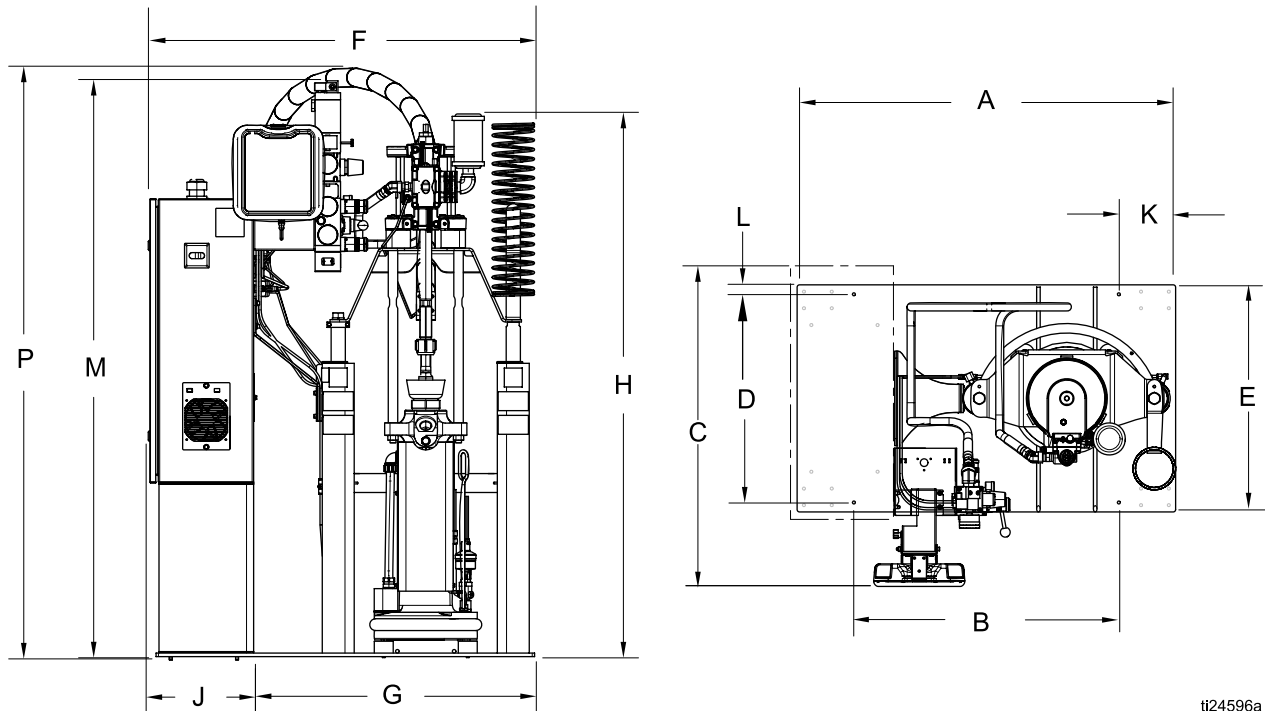

ti24596a

A	B	C	D	E	F	G	J	K	L	M	P
in.	in.	in.	in.	in.	in.	in.	in.	in.	in.	in.	in.
(mm)	(mm)	(mm)	(mm)	(mm)	(mm)	(mm)	(mm)	(mm)	(mm)	(mm)	(mm)
40	28	36	22	24	40.8	29.7	11	6 (152)	1 (25.4)	60	62
(1016)	(711)	(914)	(558)	(609)	(1036)	(754)	(279)			(1524)	(1574)

Height (H)	Dimensions
Fully Raised	74.3 in (1887 mm)
Fully Lowered	57.3 in (1455 mm)

Dimensions

15:1 Pump

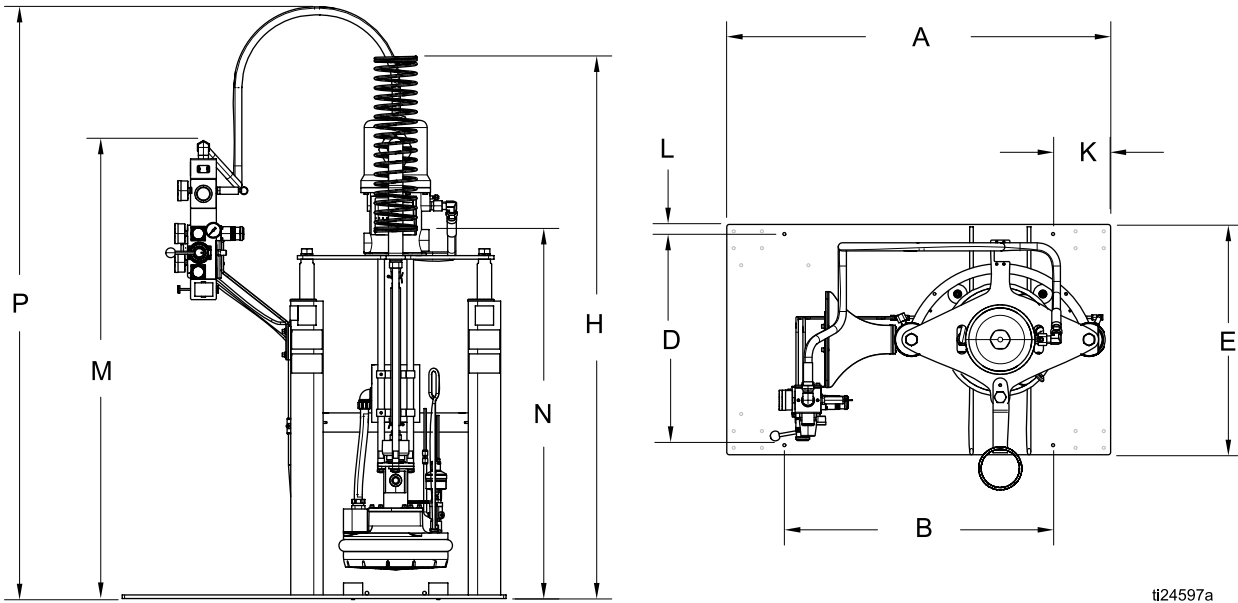

ti24597a

A	B	D	E	G	K	L	M	N	P
in. (mm)	in. (mm)	in. (mm)	in. (mm)	in. (mm)	in. (mm)	in. (mm)	in. (mm)	in. (mm)	in. (mm)
40 (1016)	28 (711)	22 (558)	24 (609)	29.7 (754)	6 (152)	1 (25.4)	48 (1219)	38.5 (977)	62 (1574)

Height (H)	Dimensions
Fully Raised	73.5 in (1866 mm)
Fully Lowered	56.5 in (1435 mm)

Technical Specifications

Therm-O-Flow 20 Hot Melt System		
	U.S.	Metric
Air inlet size	1/2 npsm(f)	
Air motor sound data	See air motor instruction manual.	
Wetted Parts	carbon steel, brass, chrome, zinc, nickel plating, stainless steel (304, 316, 440, and 17-4 PH), alloy steel, ductile iron, PTFE	
Displacement pump effective area		
Merkur and NXT	1.24 in ²	8 cm ²
President	0.884 in ²	5.7 cm ²
Volume per cycle		
Merkur and NXT	11.7 in ³	192 cm ³
President	3.8 in ³	62.3 cm ³
Pump cycles per 1 gallon (3.8 liters)		
Merkur and NXT	21	
President	61	
Ram maximum input pressure		
Merkur and NXT	100 psi	0.7 MPa, 7 bar
President	100 psi	0.7 MPa, 7 bar
President 4.25 in	100 psi	0.7 MPa, 7 bar
Maximum pump operating temperature		
Merkur and NXT	400°F	204°C
President	400°F	204°C
Pump fluid outlet size		
Merkur and NXT	1 in npt(f)	
President	1/2 in npt(f)	
Maximum Fluid Working Pressure		
Merkur 6.0 in	2300 psi	15.9 MPa, 159 bar
Merkur 7.5 in	3000 psi	20.7 MPa, 207 bar
NXT 6500	3000 psi	20.7 MPa, 207 bar
President 4.25 in	1800 psi	12.6 MPa, 125 bar
Maximum Air Input Pressure (Pumps)		
Merkur 6.0 in	100 psi	0.7 MPa, 7 bar
Merkur 7.5 in	82 psi	0.57 MPa, 5.7 bar
NXT 6500	43 psi	0.29 MPa, 2.9 bar
President 4.25 in	120 psi	0.8 MPa, 8.3 bar
Power Requirements		
Compressed Air (typical)	25-50 scfm	

Voltage (as selected)	220/240 V, 3-phase, 50/60 Hz
	380/400 V, 3-phase, 50/60 Hz
	470/490 V, 3-phase, 50/60 Hz
	575 V, 3-phase, 50/60 Hz
Peak Consumption (includes drum melt grid, pump, and a 6kVa transformer for the 230 V hoses and accessories)	
Standard melt grid platen with President pump	6.4 kVa
Standard melt grid platen with Merkur or NXT pump	8.7 kVa
Smooth melt grid platen with President pump	6.4 kVa
Smooth melt grid platen with Merkur or NXT pump	8.7 kVa

Graco Standard Warranty

Graco warrants all equipment referenced in this document which is manufactured by Graco and bearing its name to be free from defects in material and workmanship on the date of sale to the original purchaser for use. With the exception of any special, extended, or limited warranty published by Graco, Graco will, for a period of twelve months from the date of sale, repair or replace any part of the equipment determined by Graco to be defective. This warranty applies only when the equipment is installed, operated and maintained in accordance with Graco's written recommendations.

This warranty does not cover, and Graco shall not be liable for general wear and tear, or any malfunction, damage or wear caused by faulty installation, misapplication, abrasion, corrosion, inadequate or improper maintenance, negligence, accident, tampering, or substitution of non-Graco component parts. Nor shall Graco be liable for malfunction, damage or wear caused by the incompatibility of Graco equipment with structures, accessories, equipment or materials not supplied by Graco, or the improper design, manufacture, installation, operation or maintenance of structures, accessories, equipment or materials not supplied by Graco.

This warranty is conditioned upon the prepaid return of the equipment claimed to be defective to an authorized Graco distributor for verification of the claimed defect. If the claimed defect is verified, Graco will repair or replace free of charge any defective parts. The equipment will be returned to the original purchaser transportation prepaid. If inspection of the equipment does not disclose any defect in material or workmanship, repairs will be made at a reasonable charge, which charges may include the costs of parts, labor, and transportation.

THIS WARRANTY IS EXCLUSIVE, AND IS IN LIEU OF ANY OTHER WARRANTIES, EXPRESS OR IMPLIED, INCLUDING BUT NOT LIMITED TO WARRANTY OF MERCHANTABILITY OR WARRANTY OF FITNESS FOR A PARTICULAR PURPOSE.

Graco's sole obligation and buyer's sole remedy for any breach of warranty shall be as set forth above. The buyer agrees that no other remedy (including, but not limited to, incidental or consequential damages for lost profits, lost sales, injury to person or property, or any other incidental or consequential loss) shall be available. Any action for breach of warranty must be brought within two (2) years of the date of sale.

GRACO MAKES NO WARRANTY, AND DISCLAIMS ALL IMPLIED WARRANTIES OF MERCHANTABILITY AND FITNESS FOR A PARTICULAR PURPOSE, IN CONNECTION WITH ACCESSORIES, EQUIPMENT, MATERIALS OR COMPONENTS SOLD BUT NOT MANUFACTURED BY GRACO. These items sold, but not manufactured by Graco (such as electric motors, switches, hose, etc.), are subject to the warranty, if any, of their manufacturer. Graco will provide purchaser with reasonable assistance in making any claim for breach of these warranties.

In no event will Graco be liable for indirect, incidental, special or consequential damages resulting from Graco supplying equipment hereunder, or the furnishing, performance, or use of any products or other goods sold hereto, whether due to a breach of contract, breach of warranty, the negligence of Graco, or otherwise.

FOR GRACO CANADA CUSTOMERS

The Parties acknowledge that they have required that the present document, as well as all documents, notices and legal proceedings entered into, given or instituted pursuant hereto or relating directly or indirectly hereto, be drawn up in English. Les parties reconnaissent avoir convenu que la rédaction du présente document sera en Anglais, ainsi que tous documents, avis et procédures judiciaires exécutés, donnés ou intentés, à la suite de ou en rapport, directement ou indirectement, avec les procédures concernées.

Graco Information

For the latest information about Graco products, visit www.graco.com.

For patent information, see www.graco.com/patents.

To place an order, contact your Graco Distributor or call to identify the nearest distributor.

Phone: 612-623-6921 or Toll Free: 1-800-328-0211 Fax: 612-378-3505

All written and visual data contained in this document reflects the latest product information available at the time of publication.

Graco reserves the right to make changes at any time without notice.

Original Instructions. This manual contains English. MM 334129

Graco Headquarters: Minneapolis

International Offices: Belgium, China, Japan, Korea

GRACO INC. AND SUBSIDIARIES • P.O. BOX 1441 • MINNEAPOLIS MN 55440-1441 • USA

Copyright 2014, Graco Inc. All Graco manufacturing locations are registered to ISO 9001.

www.graco.com

Revision C, August, 2015